

Comprehensive training material for technicians

Belgaum foundry cluster

GEF-UNIDO-BEE Project

Promoting Energy Efficiency and Renewable Energy in selected MSME clusters in India

Prepared for:



Bureau of Energy Efficiency

©Bureau of Energy Efficiency, 2018

This document has been originally prepared by TERI as a part of 'Capacity Building of LSPs' activity under the GEF-UNIDO-BEE project 'Promoting Energy Efficiency and Renewable Energy in selected MSME clusters in India'.

Suggested Format for Citation

This document may be reproduced in whole or in part and in any form for educational and non-profit purposes without special permission, provided acknowledgement of the source is made. BEE and TERI would appreciate receiving a copy of any publication that uses this document as a source. A suggested format for citation may be as below:

GEF-UNIDO-BEE Project, Bureau of Energy Efficiency, 2018

“Capacity Building of Local Service Providers”

For more information

GEF-UNIDO-BEE PMU

Bureau of Energy Efficiency

4th Floor, Sewa Bhawan, Sector-1,

R.K. Puram, New Delhi-110066

Email: gubpmu@beenet.in

pmc@teri.res.in

Website: www.beeindia.gov.in

www.teriin.org

Disclaimer

This document is an output of an exercise undertaken by TERI under the GEF-UNIDO-BEE project's initiative for the benefit of MSME units and is primarily intended to assist the decision making by the management of the intended unit for

the proposed technology. While every effort has been made to avoid any mistakes or omissions, GEF, UNIDO, BEE or TERI would not be in any way liable to any person or unit or other entity by reason of any mistake/omission in the document or any decision made upon relying on this document

Contents

About this manual.....	1
1.0 Introduction.....	1
1.1 Background	1
2.0 Module 1 - Good practices in motor rewinding	3
2.1 Reasons of motor failure.....	3
2.2 Overview of possible motor Losses	4
2.3 Best practices in motor rewinding	5
List of references	14
3.0 Module 2 - Kaizen in induction furnace.....	15
3.1 Lean manufacturing.....	15
3.2 Case study - A foundry in Kolhapur	21
4.0 Module 3 - Energy efficiency improvements in compressed air and cooling water systems	31
4.1 Compressed air system.....	31
4.2 Cooling water system	50

About this manual

This manual provides, in a direct and simple manner, guidance on improving energy efficiency for local service providers (LSPs) in the 'Technicians' category.

The aim is to build their capacities and equip them with the necessary knowledge and skills and to provide background information and tips regards energy efficiency (EE)/renewable energy (RE) options in important foundry operation viz. Good practices in motor rewinding, Kaizen in Induction furnace and Energy efficiency in compressed air and cooling water system.

The manual is designed to complement the knowledge shared with the participants through a series of four one day training/capacity building programs undertaken by TERI in Belgaum Foundry Cluster between February to April 2018 under the GEF-UNIDO-BEE Project "Capacity Building of Local Service Providers".

1.0 Introduction

1.1 Background

The overall aim of the GEF-UNIDO-BEE project is to develop and promote a market environment for introducing energy efficiency and enhancing the use of renewable energy technologies in process applications in selected energy-intensive MSME clusters in India. This would help in improving the productivity and competitiveness of the MSME units, as well as in reducing the overall carbon emissions and improving the local environment.

The following three foundry clusters are targeted under the assignment - Coimbatore, Belgaum and Indore.

This comprehensive training material for Belgaum foundry cluster is targeted at 'Technicians' category. The material is structured in the following 3 modules.

Module 1	Good practices in motor rewinding
Module 2	Kaizen in Induction furnace
Module 3	Energy efficiency improvement in compressed air and cooling water system

2.0 Module 1 - Good practices in motor rewinding

2.1 Reasons of motor failure

Electric motors fail for a variety of reasons. Certain components of motors degrade with time and operating stress. Electrical insulation weakens over time with exposure to voltage unbalance, over and under-voltage, voltage disturbances, and temperature. Contacts between moving surfaces cause wear. Wear is affected by dirt, moisture, and corrosive fumes and is greatly accelerated when lubricant is misapplied, becomes overheated or contaminated, or is not replaced at regular intervals. When any components are degraded beyond the point of economical repair, the motor's economic life is ended. The major cause

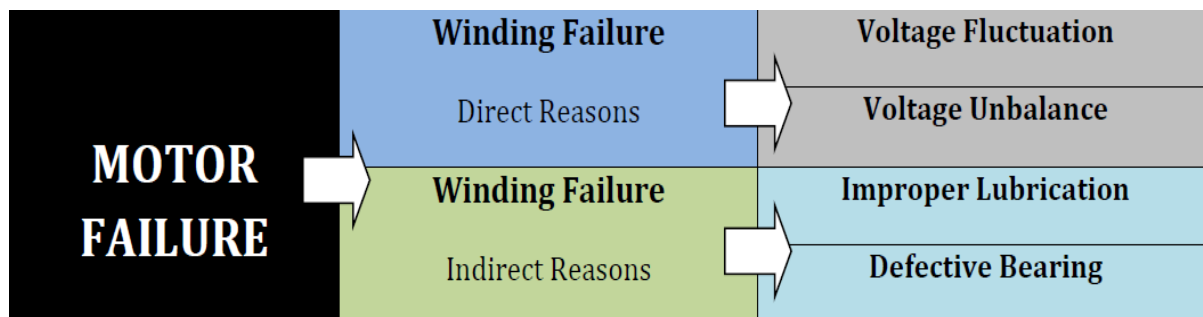

of motor failure is shown in figure.

Power quality is one of the major issues leading to motor failure. Fluctuating/low voltage from the supply side (in LT industries) and voltage imbalance (due to major concentration of single phase loads) at the motor side are identified as the major reasons of on motor failure. This seems to be the cause of winding failure because of high winding temperature resulted by high current and subsequent insulation failure. Apart from the above, O&M practices like improper lubrication or/and defective bearing (selection and installation) also play role in winding failure. This is because of high inrush current in order to overcome the friction loss. It is highly felt that awareness creation must be done among the practicing engineers on how to reduce the chances of voltage imbalance at the motor end and frictional loss in motor bearings.

Poor housekeeping and cleanliness of workplace are also other reasons contributing to failure of the motor during operation in ceramic industries. The housekeeping activities like proper maintenance of motor inventories spare parts, cleanliness of name plates/motor body surface, proper ventilation and cabling, cleanliness of MCC panels and motor junction box are very important for healthy running of the motor. Apart from this quality of earthing are important areas which should not be ignored at the unit end. A poor earthing may not necessarily result in failure of the

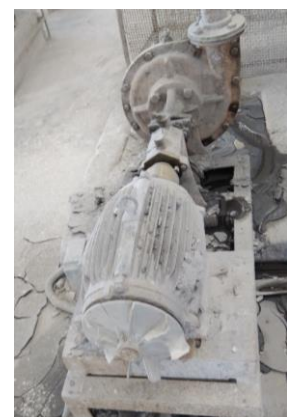

Highest efficiency motors use thin laminations of high quality steel, coated with a microfilm of varnish and these were found to exhibit no increased loss over the test range of 350 - 400°C

No load losses, stator copper losses are caused by heating from the current flow through the stator winding. Techniques for reducing these losses include optimizing the stator slot design. Rotor losses are caused by rotor currents and iron losses.

Replacement bearing & lubricants should be to the original specification and repairers should be aware that high efficiency motors use newer & sophisticated bearings.

motor but is an important part of electrical safety. Best practices in housekeeping will certainly improve the motor health further in MSMEs cluster.

2.2 Overview of possible motor Losses

The loss in efficiency on rewinding depends on the techniques, processes and skill used to perform the rewind. Based on largely on a handful of studies of mostly smaller motors (up to 30 hp or 22.5 kW), they often assert that efficiency drops 1-5% when a motor is rewound-even more with repeated rewinds. It is usually between 1 and 2%. In general, there are three factors affecting the efficiency of rewind motors



- ↪ **Increase in Iron Losses:** An increase in the iron losses can be caused
- ↪ **Mechanical stress in the core** will increase the hysteresis loss, as might happen if the core is fitted into a new frame with an undersized bore. The practice of hammering stator teeth back into place after stripping will result in increased hysteresis locally as a result of the residual stress. Eddy current loss will increase if the insulation between adjacent laminations is damaged, for example by burring together by filing or by accidental impact.
- ↪ **Thermal damage to the core:** thermal damage to the oxide or varnish insulation between the laminations is normally regarded as the usual cause of increased iron loss following a rewind. New work in which the increased loss after rewind under carefully controlled conditions for a number of motors was measured has shown that for conventional steels the temperature should not exceed 380°C. Losses increase very rapidly at higher temperatures.
- ↪ Most motors are designed to run with flux densities in the stator and rotor core just over the knee of the magnetisation curve. If the winding characteristics

are changed after rewind, for example if the numbers of turns are reduced, the flux density and hence the loss will increase.



Copper Loss: Stator copper loss is the largest loss (at full load) in most induction motors. The winding pattern may be changed during rewinding to simplify the process, and in doing so the repairer must consider the effect on flux density and resistance.

↳ These losses are reduced for example by increasing the size of the conductive bars and end rings to produce lower resistance. Stray load losses are the result of leakage fluxes induced by load currents. These can be decreased by improving slot geometry of rewound motors.

↳ **Mechanical Considerations:** The concentricity of rotor and stator is very important. It is common practice to **metal spray shafts or bearing housings** which have been damaged in service. This is acceptable only if special care is taken to preserve concentricity – errors which result in a minimum to **maximum gap ratio greater than 1:1.25** will adversely affect efficiency.

2.3 Best practices in motor rewinding

Most repair processes, if done improperly, can reduce motor efficiency. Conversely, doing them well will maintain and may even improve efficiency. It is also important to keep clear, concise written records throughout the repair process.

The following sections provide good practice procedures for each stage of the repair process, beginning with the preliminary inspection and dismantling the motors. The key recommended steps and standard/good practices is given in table below

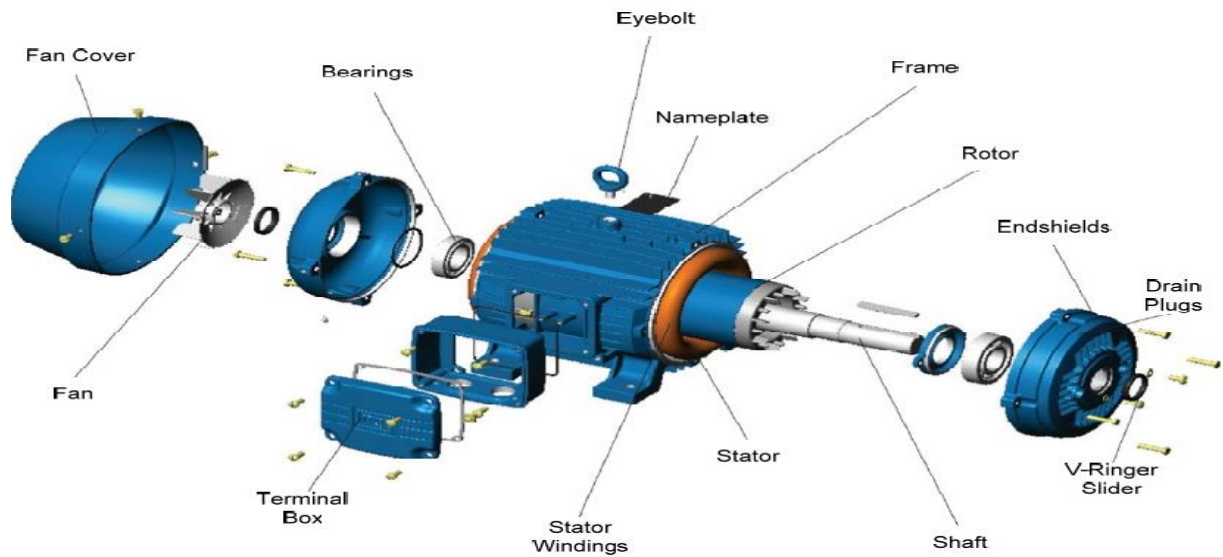

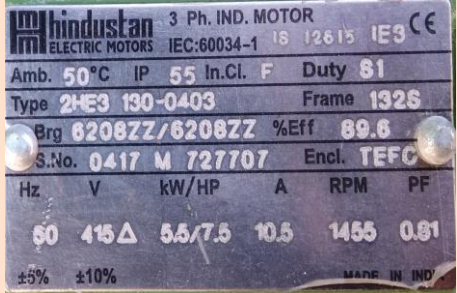

STEPS OF REPAIR PROCESSES

- Preliminary inspection
- Dismantling the motor
- Removing old winding
- Cleaning the core
- Rewinding the motor
- Reassembling the motor

Recommended procedure	Key steps	Observations
<p>Preliminary inspection (The preliminary inspection forms an important part of the complete motor repair record and may yield vital clues about the cause of failure.</p> <p>Sometimes it is obvious from its outward appearance that the returned motor is not repairable and that a new one must be supplied. More often, however, the motor must be dismantled before this decision can be made.)</p>	<p>Motor nameplate(s) data</p>	<ul style="list-style-type: none"> • Keep record of all data on the nameplate. • Check whether motor is IE efficiency class (as per IS12615). 
	<p>Results of external inspection</p>	<ul style="list-style-type: none"> • General condition—old/new, dirty/clean, etc. • Cooling air ducts clear/ obstructed – may have caused overheating. • Shaft discolored (brown /blue) – sign of rotor overheating or bearing seizure. • Parts missing, damaged or previously replaced/ repaired - e.g., seals, stator cooling ribs, fan, fan cover, terminal box, etc.
	<p>User/Customer input</p>	<ul style="list-style-type: none"> • Customers may be able to provide: • Operating environment –temperature, vibration, etc. • Type of driven equipment. • How many hours/day motor runs. • Approximate motor load. • How often it is started. • type of starter used • Rewinding history • How long the motor has operated since new (or since last rewind). • Unusual events—e.g., power outage, lightning strike, water damage, problem with driven equipment, etc.
<p>Dismantling the motor (It is essential to dismantle the motor carefully and to keep adequate records to ensure that if the motor is repaired it can be reassembled correctly. Place all parts that are not to be repaired</p>	<p>Terminal box position, layout and connections.</p>	<ul style="list-style-type: none"> • Record markings on both winding leads and terminals. • Record positions of any links between terminals (make sketch). • Check that insulation on winding leads immediately adjacent to terminals does not show any signs of

Recommended procedure	Key steps	Observations
in a suitable bin or tray that is labelled with the motor serial number or job card number.)		<p>overheating (discoloration or brittleness). If it does, replace the leads.</p> <ul style="list-style-type: none"> • Confirm that all terminals are firmly crimped or brazed to winding leads. • Record size & type of lead wire. • Record lug size and style.
	Orientation of end brackets and bearing caps.	<ul style="list-style-type: none"> • End brackets and bearing caps should be installed in exactly the same positions as originally fitted. • Mark all end brackets and stator frames at both ends of the motor (punch marking components with a center punch) before dismantling the motor
	Bearing sizes, types and clearances.	<ul style="list-style-type: none"> • Bearing enclosure • Fit and tolerance • Precision class • Internal clearance • Load application • Type of lubricant
	Axial position of rotor relative to stator (drive end - DE or opposite drive end - ODE).	<ul style="list-style-type: none"> • Rotor should be centered axially within the stator core. • If it is displaced axially, centering forces will exert pressure on the bearings. • If it is displaced beyond the end of the stator core, magnetizing current will increase. • Note position of axial thrust washer when dismantling the motor (i.e., DE or ODE).
	Orientation of shaft with respect to the main terminal box.	<ul style="list-style-type: none"> • Document the mounting position of the shaft in relation to the leads (F1 or F2). • There many ways to do this. Some repairers describe this as “leads left facing shaft” or “shaft right facing leads.”
	Careful rotor removal to prevent damage to air gap surfaces or winding.	<ul style="list-style-type: none"> • Rotor presents a considerable overhung load when one end bracket has been removed. • Allowing it to scrape along the stator bore during rotor removal can damage the air gap surfaces of both stator and rotor and increase losses. Winding damage can also result. • An effective way to remove and

Recommended procedure	Key steps	Observations
		replace rotors in horizontal motors is by using a rotor removal tool
	Internal inspection	<ul style="list-style-type: none"> • Water or dirt ingress. • Condition of stator and rotor cores—damage or overheating. • Condition of winding—discoloration, type of failure.
	Mechanical damage to components or signs of misuse.	<ul style="list-style-type: none"> • Damage to fan or fan cover • Damaged or blocked cooling ducts/channels/ribs • Shaft discoloration adjacent to either bearing (overload or misalignment)
	Motors with contamination	<ul style="list-style-type: none"> • If the exterior is packed full of contaminants, address maintenance procedures or consider a different enclosure. • If the winding is packed full of contaminants, the enclosure may not be suitable for the operating environment.
Removing the old winding and cleaning the core (Although removal of old winding and cleaning core are necessarily carried out sequentially, recording the winding details is a coordinated activity carried out both before and during winding removal. Likewise, core loss testing is carried out at fixed points throughout the process.)	Recording the winding details on appropriate data cards or sheets	<ul style="list-style-type: none"> • Winding configuration (lap, concentric, single, two or three layers, etc.) • Number of slots & poles • Number of phases • Number, size & marking of leads • Turns/coil • Grouping • Coil pitch & Connections • Coil extension/overhang—connection end • Coil extension—non-connection end • Number and size of wires in each coil
	Core loss testing	<ul style="list-style-type: none"> • Make sure the tests are conducted well within the manufacturer’s recommended operating range for the tester being used. Carry out tests: <ul style="list-style-type: none"> - Before burnout - After the core has been cleaned prior to rewinding. • Remember that figures obtained are comparative, not actual losses. • If the core loss increases by more than 20%: <ul style="list-style-type: none"> - Make sure the settings of the core loss tester have not been changed and repeat the test. - If the repeat test confirms the

Recommended procedure	Key steps	Observations
	<p>Removing old winding</p> 	<p>increased loss, repair the core or consider replacing it.</p> <ul style="list-style-type: none"> • Step 1–Cut off one coil extension (usually opposite connection end): Cut off coil extension of the winding as close to stator core as possible without damaging the stator core. • Step 2–Remove the old stator winding: Varnish and insulation must be broken down before windings to be removed. • To be with a controlled temperature burnout oven. Coils must be heated sufficiently to burn out old insulation from windings without damaging interlaminar insulation. • It is important to set the oven temperature to monitor the temperature of the stator core. (See figure). • Key points–removing the old windings <ul style="list-style-type: none"> ○ Cut off one coil extension using a winding cut-off machine. ○ Burn out old insulation at appropriate temperature in a controlled-temperature burnout oven set to monitor core temperature. ○ Do not overheat the core. Remove the winding without damaging the core.
	<p>Cleaning the stator core in preparation for rewinding</p> 	<ul style="list-style-type: none"> • Key points–cleaning the stator core: <ul style="list-style-type: none"> ○ Careful scraping with a sharp knife. ○ High-pressure washing. ○ Blasting with a mildly abrasive material. ○ Brushing with medium/soft wire brush. • After cleaning the slots: <ul style="list-style-type: none"> ○ Reposition damaged teeth ○ Repair minor damage to air gap surfaces • Replace or reinsulate and rebuild cores if major damage has occurred

After performing the inspection and removal the winding, if choosing the replacement of winding the repairer has two options:

- Copy (duplicate) the winding already in the motor (provided it is the manufacturer's original).
- Choose a different style of winding that will perform as well as or better than the original.

At this stage, the repairers have opportunity to redesign the motors to make them more energy efficient. Most of the time, however, the best way to maintain motor efficiency is to duplicate the original winding, while increasing the copper cross sectional area as much as possible and keeping the end turns as short as possible (certainly no longer than those of the original winding).

When production volume justifies the cost, motor manufacturers use automatic coil winding and inserting machinery to produce motors with concentric coil groups. Repairers often find lap windings much quicker and easier to install.

This section therefore sets out the basic rules (in terms of maintaining efficiency) for just two types of rewind:

- A "copy" (or duplicate) rewind
- Changing the original concentric winding to a conventional lap winding

Recommended procedure	Key steps	Observations
-----------------------	-----------	--------------

Though, that in some designs, the coil extension is critical for heat dissipation. If it is too short, the temperature of the winding may rise, causing I^2R losses to increase.

Recommended procedure	Key steps	Observations
Rewinding the motor	Copy (duplicate) rewinding	<ul style="list-style-type: none"> • If the details of old winding have been recorded, and provided that it is the manufacturer's original winding, the core can now be prepared for rewinding. • Even though the coil pitch (or pitches), turns/coil and the connections will be the same as those of the original winding, two changes could be made that will help to maintain or even slightly improve the efficiency of the rewound motor: <ul style="list-style-type: none"> • Minimize the length of the coil extensions. • Increase the copper cross-sectional area in each coil. • Key points-copy rewinding <ul style="list-style-type: none"> ○ Check that old winding is manufacturer's original. ○ Use same winding configuration. ○ Keep coil extensions as short as practical. ○ Same (preferably less) length of overhang. ○ Use same coil pitch (or pitches). ○ Use same turns/coil. ○ Use same (preferably larger) copper cross-sectional area. ○ Use same or shorter mean length of turn (MLT). ○ Use same or lower winding resistance (temperature corrected).
	Minimize the length of the coil extensions	<ul style="list-style-type: none"> • It is important to keep the coil extensions as short as possible. • Attention to the following rules will prevent this: <ul style="list-style-type: none"> ○ Keep the coil extensions within the measured dimensions of the original winding. ○ Do not extend the slot insulation beyond the slot ends any more than is necessary to prevent strain on the slot cell. ○ Do not extend the straight portions of the coil sides any farther than is necessary to clear the slot insulation. • Reducing the length of the coil extension will reduce the amount of copper in the winding and reduce losses.
	Changing to a two-layer lap winding	<ul style="list-style-type: none"> • Repairers often prefer to use lap windings because all coils are the same. This is acceptable if the new winding has the same flux/pole as the original. • Single-layer lap windings are sometimes used for small to medium-sized motors, because the coils are easier to insert and no separators are required. This allows more room for copper. • Double-layer windings distribute flux through the core better than single-layer windings. Replacing a double-layer winding with a single-layer winding will certainly reduce motor efficiency, so it is not recommended.

Recommended procedure	Key steps	Observations
<p>Completing the winding (After fully inserting the winding, connect the coils and leads to match the original connections exactly (if a copy or duplicate rewind) or appropriately for the replacement lap winding. Use connection leads that are as large as practical and mark all of them correctly. Brace the coil extension either as the manufacturer’s original winding or better (i.e., more rigid). After checking the coil extensions a final time, perform winding resistance, insulation resistance, phase balance and voltage withstand tests)</p>	<p>Winding resistance tests</p>	<ul style="list-style-type: none"> Lap windings should be appropriately short-pitched (i.e., the coil pitch must be less than the pole pitch unless the winding has only one coil per group). Measure resistance of first coil group wound and compare it with the calculated resistance. If possible, measure the resistance of a coil group from the original winding for comparison. Measure the ambient air temperature (T_a) with the winding at room temperature. Correct both resistances to a convenient common reference temperature (normally 25°C) using the formula: <div style="text-align: center;"> $R_x = \left(\frac{234.5 + 25}{234.5 + T_a} \right) \times \text{Measured resistance}$ <p>Where R_x = corrected winding resistance T_a = ambient air temperature</p> </div> The corrected value of resistance of the new coil group must be equal to or lower than that of the original coil group. When the stator is fully wound, measure and record the resistance of each phase (or between leads) as well as the ambient temperature. Resistance of each should be equal within 5% (See figure)
	<p>Phase balance (or surge comparison) tests</p>	<ul style="list-style-type: none"> Perform on completed winding before impregnation. Test compares decay rate of identical voltage pulses applied simultaneously for 2 winding phases. Trace pattern indicates phases identical (okay-identical traces) or different (fault-traces do not match). Trace pattern gives guidance to type of fault (see equipment manufacturer’s guide).
	<p>Impregnation</p>	<ul style="list-style-type: none"> Impregnating the winding with varnish and subsequently air drying or baking this varnish until it is cured serves the



Recommended procedure	Key steps	Observations
		<p>several purposes:</p> <ul style="list-style-type: none">○ It provides a mechanical bond between conductors.○ It increases the dielectric rating of the insulation.○ It protects the winding from moisture and contamination.○ It fills the air spaces between conductors (particularly in the slots). <ul style="list-style-type: none">• Lower winding temperature = lower resistance = lower I^2R losses

List of references

International Copper Association India (Effect of Repair/Rewinding On Motor Efficiency © 2003, Electrical Apparatus Service Association, Inc.)

3.0 Module 2 – Kaizen in induction furnace

3.1 Lean manufacturing

The lean approach is primarily based on finding and removing wasteful steps that do not add value to the end product. There's no need to reduce quality with lean manufacturing – the cuts are a result of finding better, more efficient ways of accomplishing the same tasks. Lean manufacturing is not only aimed at the elimination of waste in every area of production but also focuses on the activities which will help for good customer relations/satisfaction, production machine layout, waste reduction and factory management.

3.1.1 Objective

The objective of a lean approach to manufacturing is to maximize the value of the product to the customer while minimizing waste. Many companies in the manufacturing industry use lean manufacturing principles (LMP) to maximize their profit, minimize their cost of production, and eliminate waste. The goal of lean manufacturing is to incorporate less human effort, less inventory, less time to manufacture products, and less space and to become highly responsive to customer demand, while at the same time producing top quality products in the most efficient and economical manner. Lean principles can be applied to nearly anything from optimizing management to developing vertical and horizontal integration that help with optimizing the flow of products.

The lean manufacturing adopts a customer-value approach that focuses on the question "What is the customer willing to pay for?" Customers want value, and they'll pay only if needs are met. They should not pay for defects, or for the extra cost of having large inventories. In other words, customer should not be made to pay for a unit's waste. Waste is anything that doesn't add value to the end product.

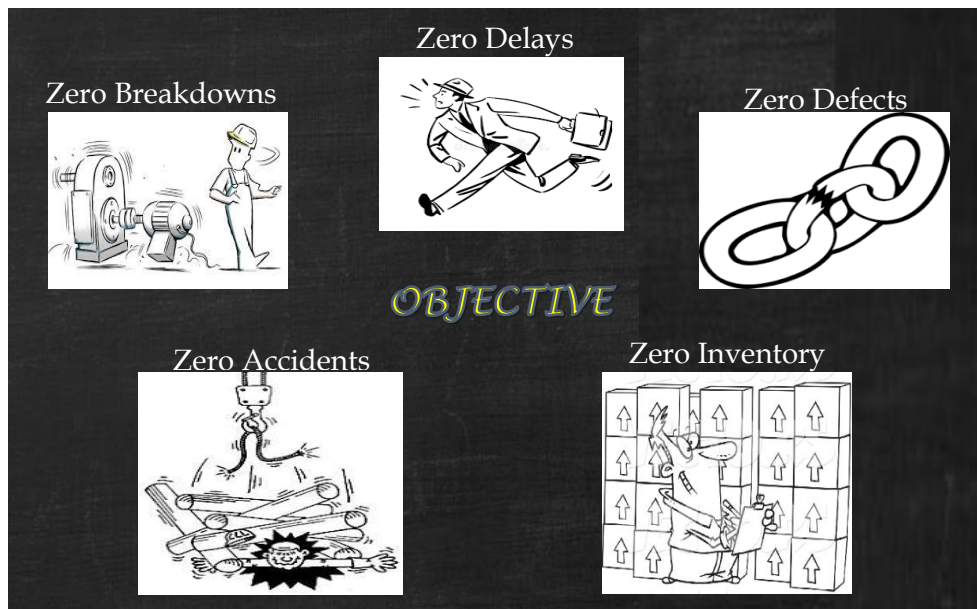

Figure 3.1.1a: Objectives of Lean Manufacturing

Principles of Lean

Lean manufacturing is a series of applied processes and tools that eliminate waste from production. Improved efficiency, effectiveness, and even profitability are all byproducts of lean manufacturing. A unique feature about lean manufacturing is that it focuses more on perpetual improvement of products rather than the final output. By shifting the attention to the process in which the product is made, defaults are minimized, the right raw materials are used, people are properly organized and coordinated, and the costs of production are properly optimized. For the process to work effectively, the manufacturing industry should consider the following five principles that will help in implementing lean techniques:

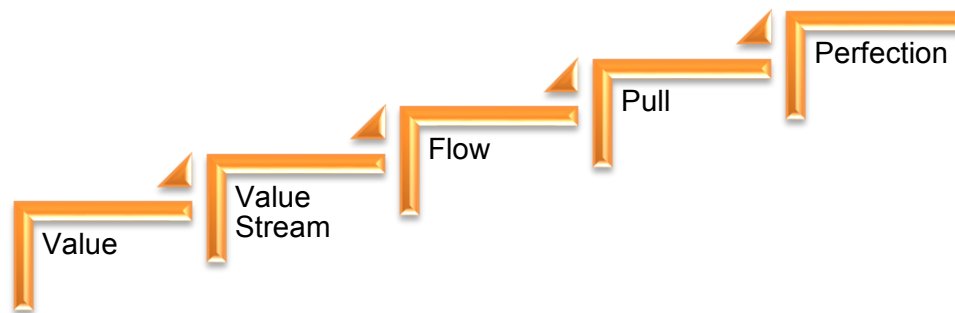

Figure 3.1.1b: Five Principles of lean

The lean management works through a number of concepts, a few of them are:

- Kaizen (continuous improvement)
- 5S and visual management
- Root cause analysis
- Value stream mapping (VSM)
- Poka-yoke (error proofing)
- Total productive maintenance (TPM)
- Just-in-time (JIT)

The focus of this module is on Kaizen for improving energy efficiency and productivity in melting area vis-à-vis. induction furnace.

3.1.2 Kaizen

The Japanese word kaizen simply means "change for better". It is a Japanese business philosophy of continuous improvement of working practices, personal efficiency. The content of Kaizen activities stipulated is as follows:

- 5S (3S) activities: Seiri (Sort; orderliness), Seiton (Set in order; neatness and tidiness), Seisou (Shine; cleanliness), Seiketsu (Standardize) and Shitsuke (Sustain)
- Adoption of suggestion system: Combined usage with petit suggestion system
- Small group activities: Visibility management of data and conditions that allow recognition of workplace problems as problems





5S – Workplace Organization

5S is a technique originated from Japan and it was first developed by Hiroyuki Hirano in 1980s. The 5S philosophy focuses on simplification of the work environment, effective workplace organization, and reduction of waste while improving safety and quality. It allows the enhancement of efficiency and productivity. The 5S technique is a structured program to systematically achieve total organization cleanliness and standardization in the workplace. The benefit of 5S technique is improvement in productivity, quality, health and safety. Through 5S methodology, the management can create an environment where quality work is comfortable, clean and safe in the organization and it can ensure the compliance to standards and will further foster continuous improvement. The term “5S” is derived from five Japanese words Seiri (Sort), Seiton (Set in order), Seiso (Shine), Seiketsu (Standardize) and Shitsuke (Sustain).

Sorting – Separating the needed from the unneeded. Sorting activities aim to eliminate unneeded items from the work area and to perform an initial cleaning. Sorting clears the deck for the remaining activities. The steps of sorting are:

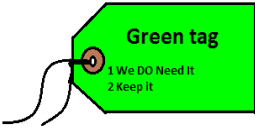
- Establish criteria for what is not needed. For example, if something hasn’t been used for a year, it may be a candidate for disposal
- Identify the unneeded items and move to a holding area
- Dispose of the not needed items, either by transferring to a department that needs them, selling them, or discarding them
- Conduct an initial cleaning

Table 3.1.2a: Tagging criteria & recommended action

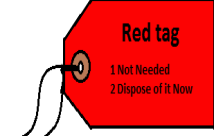
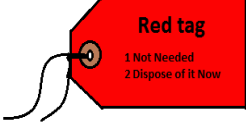
Priority	Frequency of use	Action Required	Tag
High	Daily	Store at the workplace, where it is needed and is easily assessable	
Medium	Once per week, once per month	Store together, near the workplace	 OR 
Low	Less than once per year	Throw away, or store away from the workplace	 OR 
No	Unusable items	Throw away	

Setting in Order – Once the initial sorting is completed, the natural sequence is to get the work area organized. After initial sorting the unit will be benefitted with approximately 20% of space saving. The disposable items should be tagged red. The setting in order of things will most efficiently be stored as required. Frequently-used items must be as close to where they are used as possible. The steps of simplifying are:

- Determine a location for each item based on frequency of use and proper safety zone (decreasing the likelihood of strain injuries, for example)
- Develop shadow boards and label items - a home for everything
- Determine how to replenish supplies
- Document layout, equipment, supplies and agreements for returning items

Shine – The third step in the 5S process initiates a work ethic of keeping everything clean and in order at all times. Examples of shine include wiping machinery, sweeping, tightening loose belts or bolts, cleaning gauges and indicators, tracking the source of leaks, overheating or undue noise, and organizing papers and books on office desks and shelves. Systematic cleaning provides a way to inspect, by doing a clean sweep around a work area. This means visually as well as with a broom or rags. The idea is make the job of doing daily cleaning and inspections easier. The steps of systematic cleaning are:

- Identify points to check for performance
- Determine acceptable performance
- Mark equipment and controls with visual indicators
- Conduct daily cleaning and visual checks

Standardize – The first three steps will slip unless standardized procedures, schedules and expectations are clearly identified and regularly measured. Standardizing assures that everyone knows what is expected. Since the workplace team establishes the standards, everyone should have had some involvement in establishing the 5S in their work area. Still, it is important to make these standards very clear. The steps in standardizing are:

- Establish a routine check sheet for each work area. The check sheet is like a pilot's pre-flight check list. It shows what the team should check during self-audits
- Establish a multi-level audit system where each level in the organization has a role to play. 5S system evolves and strengthens
- Establish and document standard methods across similar work areas
- Document any new standard methods for doing the work

Sustain – In order to sustain improvements made during deployment of the first 4S's, old inefficient habits will have to be removed. Changing the culture and instituting new habits will demand time and attention. It would not happen by itself. Sustaining is usually thought of as the toughest "S." However, the trick is to let the 5S system work, engage everyone in the work area during 5S activities and have a "tell at a glance" visual workplace to sustain

easily. That is important, but not sufficient. A more systematic way to prevent backsliding and to foster continuous improvement is needed. The steps of sustaining are:

- Determine the 5S level of achievement - the overall grade
- Perform worker-led routine 5S checks using the 5S check list
- Address backsliding and new opportunities found during routine checks
- Conduct scheduled, routine checks by team leads or supervisors or by people from outside of the workgroup

Perform higher-level audits to evaluate how well the 5S system is working overall. For example, are there systemic issues with sustaining 5S? Often, the company’s safety committee is an excellent body for conducting these audits.

5S Implementation Committees

The launch of 5S activities should involve a declaration by the Chairs of Implementation Committees in front of all employees. Activities should be carried out to follow a set schedule for implementation procedures. Each group should consult with the group leader to determine the theme for each month and activities should be carried out by the group based on this theme. Selection of activities and themes should be clarified and consideration given to linking to results in productivity enhancement, quality improvement, and ensuring safety.

Development of action plans

An example of a schedule for implementation procedures is shown below. The activity period of each item is decided based on discussion with implementation offices. Implementation offices should provide advice to groups that fall behind schedule or suggestion extensions of activity periods.

Table 3.1.2b: 5S implementation schedule/plan

	Jan	Feb	Mar	Apr	May	Jun	Jul	Aug	Sep	Oct	Nov	Dec
Prior preparation	→											
Clarification of policy, elaboration of 5S standard		→										
Seiri (Sort) and Seiton (Set in order) Red-tagging, signboard operation			→									
Seisou (Shine) Daily cleaning, cleaning check						→						
Seiketsu (Standardize)										→		
Shitsuke (Sustain)											→	
Summary of activity and standardization												

Defining and clarification of problems

Problems at factory sites are never-ending. In order to develop problem-solving activities in small group activities, the nature of problems must first be clarified. Problems are...

- “matters that require solutions”;
- “matters related to persons or their organisations that must be solved or improved”

In “Quality Control” problem-solving methods, the —problem is defined as the gap between the ideal situation and objectives and the present situation.

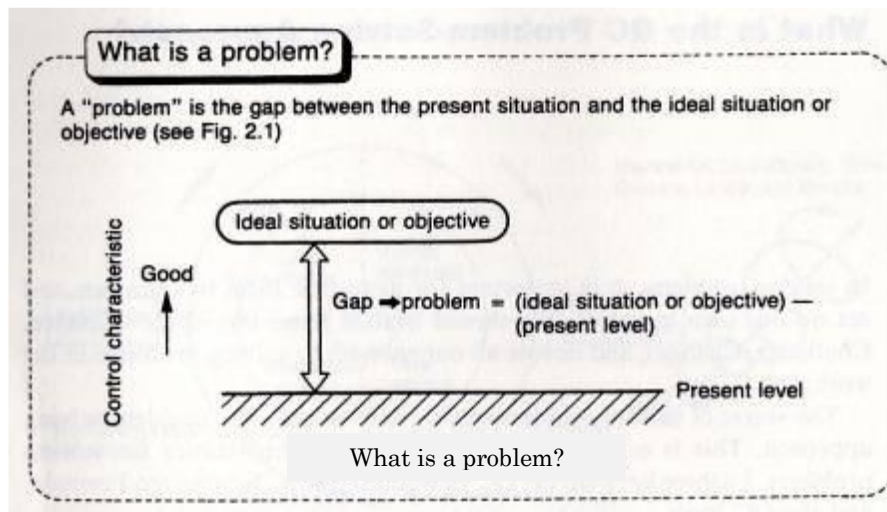

Figure 3.1.2a: What is a problem?

In “Quality Control” problem-solving methods, the —problem is defined as the gap between the ideal situation and objectives and the present situation. In order to improve workplace skills, difficult problems should be actively addressed.

Visualisation of operation data

Operational data serves as information for devising important improvements. Data becomes valuable only when understood by people. The key to understanding is converting data into formats perceptible to the human eye. Through conversion and management of all kinds of operational data on production sites into graphs, figures and tables, it is possible to ascertain abnormalities that occur on a daily basis at production sites.

In many cases, visualisation reveals problem points that were not evident in mere lists of numbers.

Different types of graphs are available for visualization of the measured data, a few of them are:

- Bar graph: To compare the size of numbers or amounts
- Line graph: To show changes in numbers and amounts
- Pie chart: To show breakdown of percentages
- Pareto chart: To analysis data with combination of bar and line graph

- Scatter plot: To display values of two variables

Sample of the above mentioned graphs/charts is shown in figure.

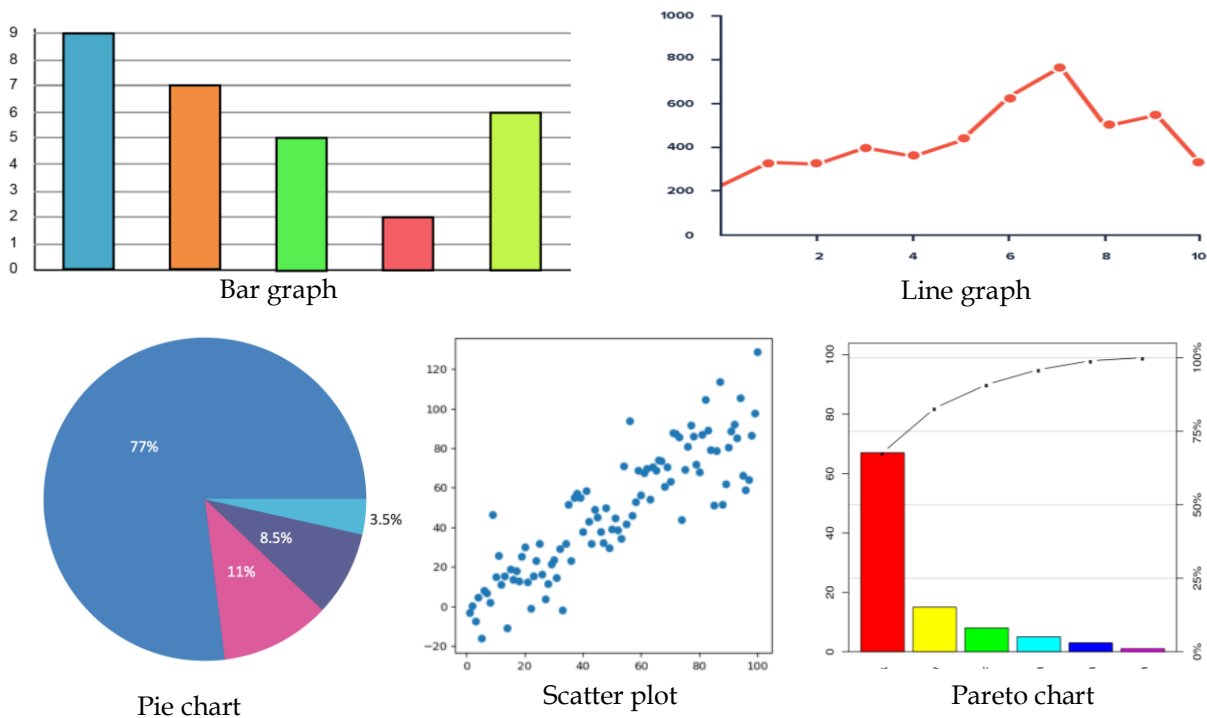

Figure 3.1.2b: Visualization of data

3.2 Case study – A foundry in Kolhapur

With focus on improving productivity and enhancing energy efficiency in melting section of the foundry a Kaizen implementation activity was planned. The following section presents findings from application of Kaizen, 5S and small group activities in a MSME foundry.

3.2.1 Background about the unit

A medium scale foundry in western region (Kolhapur) established in the 1990s with an annual production of 1,450 tonne of salable casting (FY 2014-15). The foundry produces grey cast iron castings for end-use sectors including but not limited to automobile, air compressors, tractor, railway and textile. The melting operation in the foundry was done using induction furnace. It was equipped with a 500 kg induction furnace powered by 550 kW SCR based power pack.

3.2.2 Kaizen implementation methodology

The implementation of Kaizen was carried out by the foundry team with support from external experts. The implementation of the Kaizen was as follows:

- Formation of implementation support group
- Formation of small groups
- Formulating criteria and means of evaluation of the activities

- Data collection, analysis and visualization
- Identification of problem statements
- Looking for solutions with help of “small group activity”
- Validation and implementation of suggested solution
- Post implementation verification by data collation

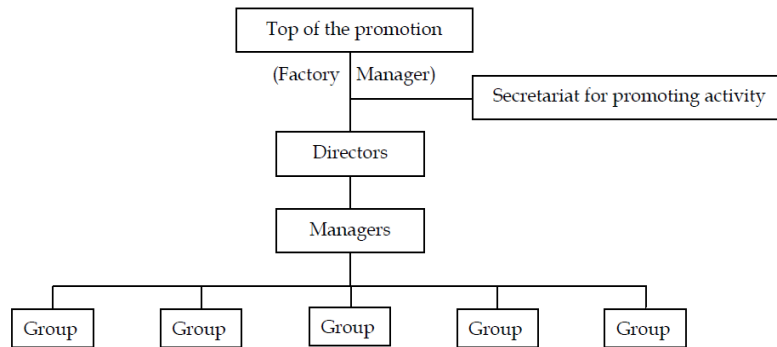

Figure 3.2.2: Implementation support group

3.2.3 Data collection, visualization and analysis

Data collection

A number data pertaining to melting operation in induction furnace were collected. A standard format was prepared in agreement with the foundry and data was collected on heat-wise basis for months. The present case study data of 545 heats of FG220 grade casting is presented. A sample format of data collection sheet is shown in table 3.2.3a, b & c.

During the first phase of Kaizen, data was collected for a number of batches. The foundry produced following grades FG220, FG260, FG300 and FG350. The data collected during Kaizen pertaining to most common grade i.e. FG220 was analysed and is presented in following section. Important parameters are defined as follows:

1. Melt no. : The heat number of the batch
2. SEC : Specific energy consumption i.e. electrical energy consumed per tonne of raw material input (UNIT: kWh/t)
3. TTT : tap to tap time for one batch i.e. from start of raw material charging to end of liquid metal tapping (UNIT: minutes)
4. TT : Tapping temperature of liquid metal (UNIT: °C)
5. Operator : The person who operates the induction furnace

Table 3.2.3a Data collection format – Part 1

Melt No.	Date	Operator Name	Material Grade	Charging Weight (kg)					Supplementary Material (kg)		Total kg
				Pig iron	Steel Scrap	C.I Scrap Boring	Domestic Scrap (RR)	Heel Metal	Innoculant	Graphite Agent	
1											
2											
3											

Table 3.2.3b Data collection format – Part 2

Time & Power Meter Readings										Total Time (min)	Total Power (kWh)	Total Power (kWh/t)	
Material charging start		Material charging End		C.E. Meter Check		Tapping Temp.	Tapping start		Tapping End				
Time	Power	Time	Power	Time	Power		Time	Power	Time	Power			

Table 3.2.3c Data collection format – Part 3

Melt No.	Material Grade	Time & Power Meter Readings				Total Time (min)	Total Power (kWh/t)	Standard Chemical Composition (%)						
		Tapping Temp.						C	Si	Mn	P	S	C.E	
1														
2														
3														

Visualization and analysis of data

A number data visualization tools were utilized to analyse the date collected. The following analysis was conducted to improve understanding of the induction furnace operation:

Table 3.2.3d: Data analysis vs. visualization tool

S. No.	Data analysis	Visualization tool
1	Melt no. vs. SEC	Line graph
2	TTT vs. SEC	Scatter plot
3	TT occurrence	Histogram
4	TT vs. SEC	Scatter plot
5	SEC vs. Operator	Line graph
6	Rejection vs. Occurrence	Pareto chart

Melt no. vs. SEC (Line graph)

A total of 545 heats of FG220 grade melting were recorded. A line graph was plotted for SEC vs. melt number. Local averages were highlighted to show the variation in SEC over time. The local averages of SEC varied from 655 to 559 kWh per tonne.

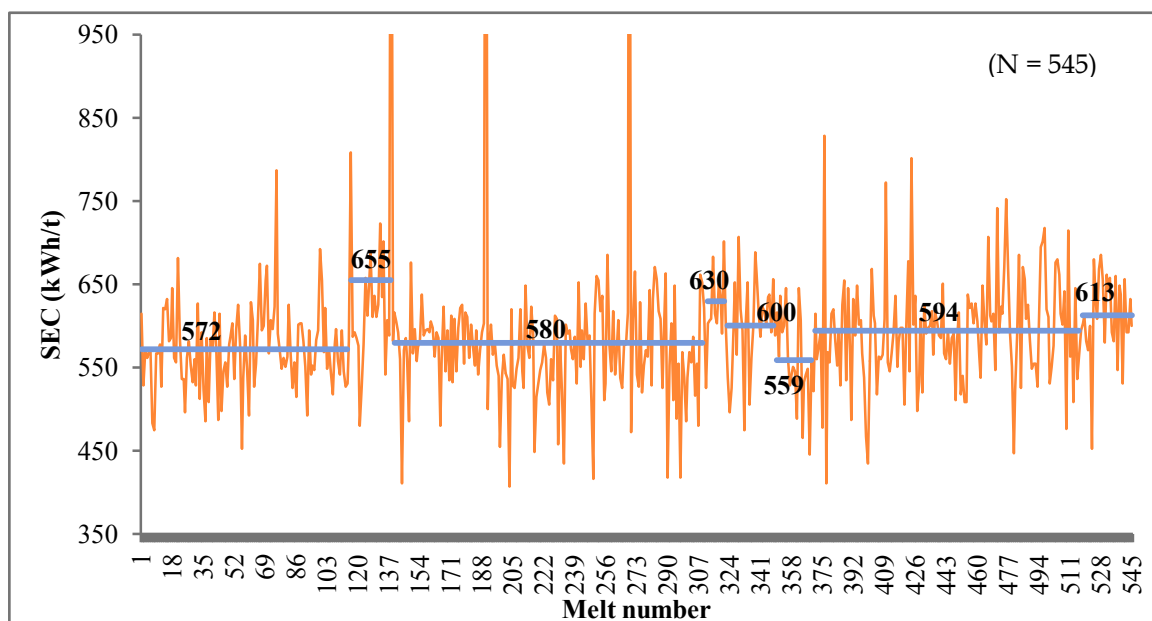

Figure 3.2.3e: Melt number vs. SEC

TTT vs. SEC (Scatter plot)

The tap-to-tap time of the heat varied depending on a number of parameters such as raw material availability, rate of charging, readiness of moulds, and delay in chemistry adjustment. A scatter was plotted for tap-to-tap time vs. the specific energy consumption. The cold start heat were omitted from this analysis, a total of 491 heats were represented.

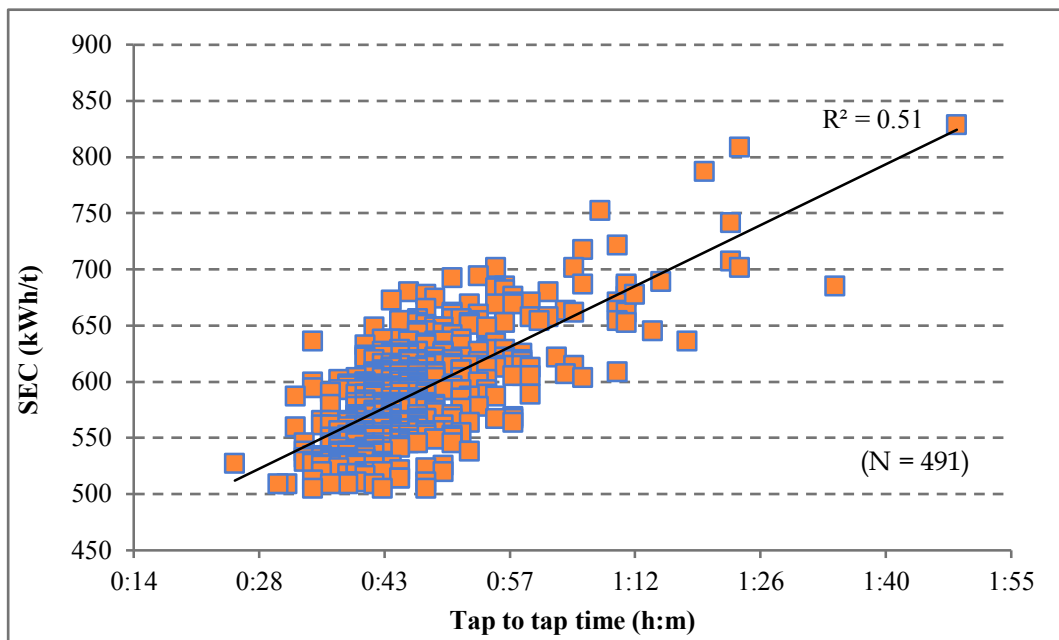

Figure 3.2.3f: Tap to tap time vs. SEC

Tapping temperature occurrence (Histogram)

A total of 528 heats were observed where tapping temperatures data was available. The range of tapping temperature was from 1442 to 1527 °C, with a median at 1469 °C. The data was evenly balanced as the mean and the median were same. The frequency of occurrence of tapping temperature in range of one standard deviation from mean is expected to contain 90% of heats. But for the foundry it was 84% meaning a scope of improvement of tighter control of tapping temperature.

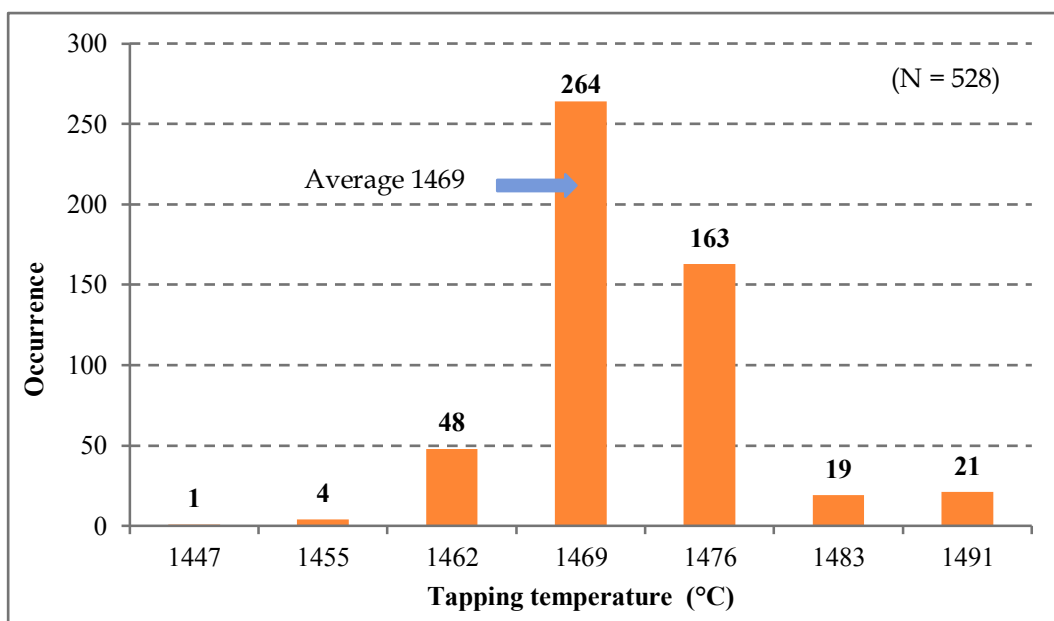

Figure 3.2.3g: Tapping temperature occurrence

Tapping temperature vs. SEC (Scatter plot)

The tapping temperature required for FG220 grade was in range of 1465 – 1475 °C. The SEC of the furnace is believed to have strong correlation with tapping temperature. A scatter plot for 465 heats for tapping temperature and specific energy consumption is shown in figure.

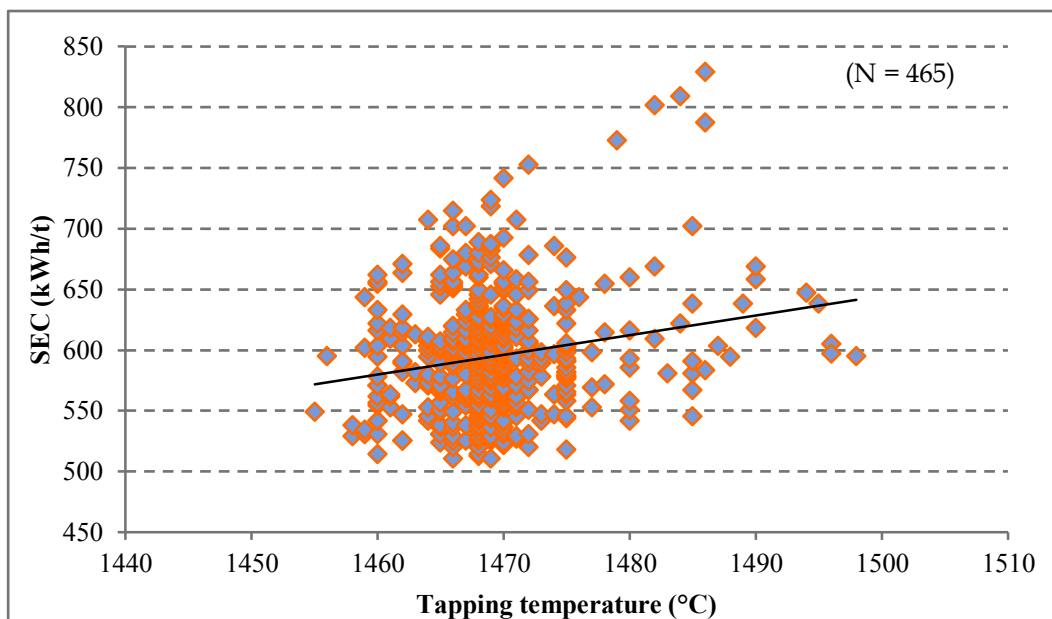

Figure 3.2.3h: Tapping temperature vs. SEC

SEC vs. operator (Line graph)

The plant had employed a total of four operators. They took different shifts. Two operators i.e. Operator 1 and Operator 2 were experienced and it reflected in their operation, their respective SEC for a sample of 26 heats was 588 and 584 kWh per tonne. The other two operators were young and new to induction furnace operation hence had slightly higher SEC of 606 and 616 kWh per tonne respectively.

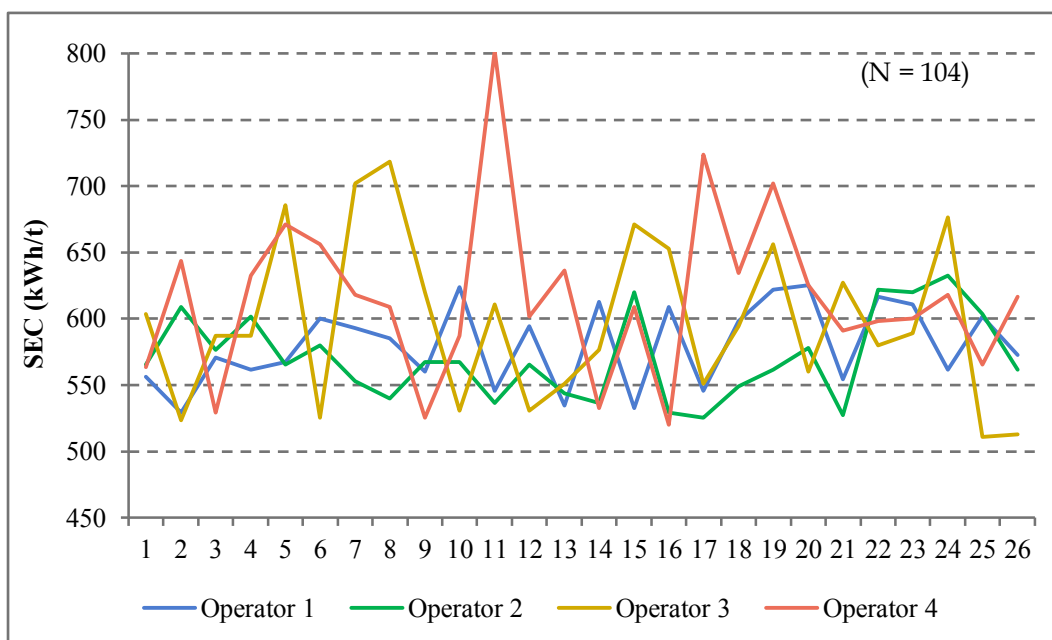

Figure 3.2.3i: Operator vs. SEC

Rejection occurrence (Pareto chart)

The rejections during the Kaizen period were recorded and categorised based on the reasons. A number of reasons were observed which on discussion with the small group led to identification of seven major types of defects/rejections. A Pareto chart was plotted for analysing the defects and to prioritize which cause has to be targeted first.

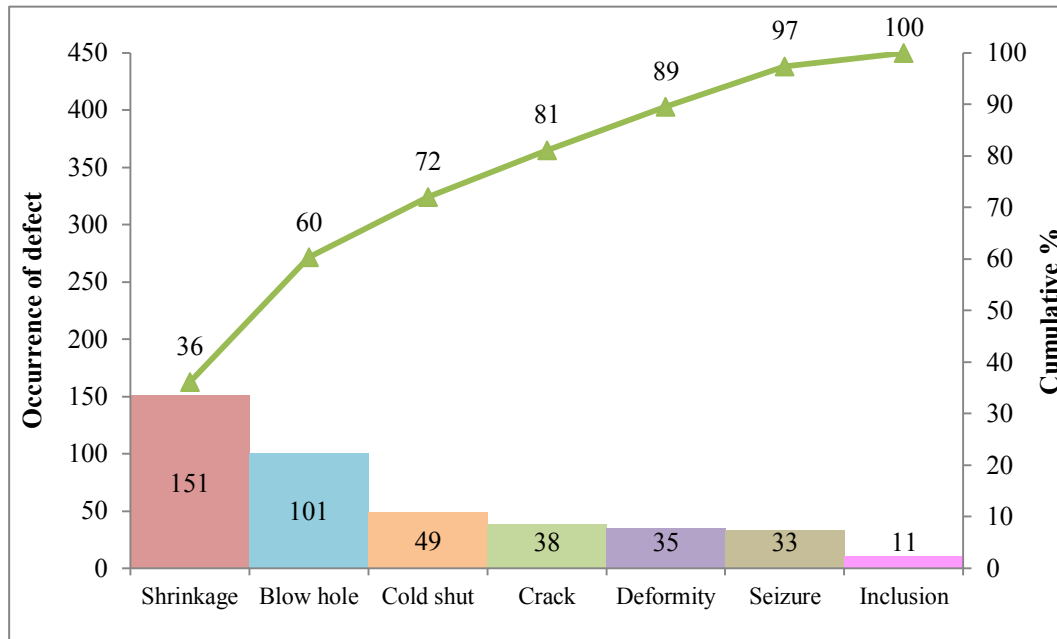

Figure 3.2.3j: Rejection analysis

The following observations were drawn based on visualization and analysis of collected data for induction furnace for melting:

- The average specific energy consumption for the 545 heats was 588 kWh per tonne. But when looked at local averages it was observed that there are instances (few heats/days) when the local average SEC is as high as 655 kWh per tonne.
- A scatter between SEC and tap to tap time shows a correlation of 0.51. In two standard deviation range about 83% of the heat fell i.e. tap to tap time in range of 37 to 59 minutes.
- The tapping temperature was looked into for variations; it was observed that only about 84% of the heats have their tapping temperature in range of one standard deviation i.e. 1462 to 1477 °C.
- The specific energy consumption had a direct positive correlation with the tapping temperature i.e. with rise in tapping temperature the specific energy consumption of the induction furnace also increased
- Observations were drawn on four operators. It was observed that the more experienced and trained operators had better specific energy consumption (584 kWh per tonne). The two fresh operators with relatively scarce experience and training had a higher specific energy consumption 606 and 616 kWh per tonne respectively.
- Seven major types of defects were identified in the foundry, a Pareto analysis showed that shrinkage was the major culprit and was responsible for about 36% of total rejections in the foundry, followed by blow holes at 24%.

3.2.4 Activities for implementation

According to the analysis of the operation status, it is found that there are large variation range of the time and the power consumption rate of the 'Tap to Tap' at each melting, specific energy consumption and also the gaps of results among the furnaces of each unit. The draft proposals of matters which the expert thinks necessity of starting the Kaizen activities for power consumption reduction of high-frequency furnace immediately are summarized below with priority. Proposal of activities proposed for implementation by various small groups are as follows:

Table 3.2.4: Proposal of activities

Category	Draft Proposal of Theme of Activities	Priority
Operation of high frequency induction furnace	Creation of the check standard list based on the past troubles	△
	Creation of the prior checking standard for oil pressure and water system	△
Maintenance of high power factor operation	Prior-operation check of the installation state of magnetic shield board	◎
	Connection situations, and cleaning situation of bus bar, etc.	◎
Heat radiation from furnace body	Heat radiation from cooling coil (amount of cooling water)	○
	Heat radiation from an outer wall (furnace building plan, consideration of insulation)	△
Shortening of materials charging (input) time	Form (shape) of input materials, proper charging amount	◎
	Mixing of different materials (Prevention from adhesion of slag, sand, refractory, etc.)	◎
Melting operation	Prevention from overheat of molten metal in operation	◎
	Consideration of heat radiation prevention cap from molten metal surface	◎
	Creation of operation melting work standard	◎
Management of the ladle preheat	Enhancement of back (rear) insulation	○
	Consideration of ladle cap	△
Creation of production plan and accomplish	Reduction of residual hot water, reduction of waiting time of mould	△

Priority: ◎ Taking immediate action is recommended,
○ Taking an action not immediately but sometime after is recommended,
△ Taking an action carefully and thoroughly

3.0 Module 2 – Kaizen in induction furnace

The foundry implemented the draft proposals based on the priority level. A pictorial view of some of the implemented measures is shown in figure 3.2.4.



Installation of induction furnace energy monitoring system



Lid mechanism for induction furnace crucible



Proper sizing of pump and improving energy efficiency



Removal of obstruction to cooling tower air intake and FRP blades

Figure 3.4: Pictorial view of a few implementations

3.2.5 Results

The first phase of Kaizen was dedicated to monitoring, visualization and analysis of data. The phase two of the Kaizen was focussed on getting proposals from small groups, validating them and prioritising proposal for implementation. In third phase proposals were implemented and in final phase measurements were conducted to verify the results.

The specific energy consumption came down from 588 to 559 kWh per tonne. The rejection level came down from 418 pieces per month to 335 pieces per month.

List of references

Bureau of Energy Efficiency Guide Books – Furnace

Kaizen activity manual for Indian foundry units, Prepared by TERI

Best Operating Practices in foundry, prepared by TERI

TERI – Past studies on foundries

4.0 Module 3 – Energy efficiency improvements in compressed air and cooling water systems

4.1 Compressed air system

4.1.1 Background

Air compressor is a device, which is operated with the help of connected electrical motor or other mechanical device to compress and pressurize air as per the set operating condition. The pressurized air is stored in a receiver tank and distributed to the point of use through piping network.

In metal casting industries, the air compressors are mainly used to deliver service air to various connected utilities as employed in the process. The micro scale foundry use reciprocating air compressor as the demand is intermittent and very low. However the small scale foundries use one or multiple screw type air compressors for meeting the compressed air demand.

Compressed air is highly energy intensive as only 10 to 30% of the electrical energy consumption of an air compressor is usefully converted into compressed air and the balance is lost as unusable heat energy. A lifecycle cost assessment of compressed air system shows about 75% of total cost is towards energy. A number of studies have revealed that by proper management, energy saving in tune of 10 – 50% can be achieved in a compressed air system.

Reciprocating air compressor

Several types of reciprocating compressors are available, namely, single- or multi-stage, lubricating and non-lubricating, and single- and double-acting. Single-stage compressors are normally used for a pressure ratio of up to four, while multi-stage compressors are economical for situations above this ratio. Other associated advantages of multi-stage compressors are reduced air temperature and pressure differential, which reduces the load and stress on valves and piston rings. Non-lubricating compressors are especially used for providing air to the instruments and for processes that require oil-free air. Double-acting compressors are used for higher capacities, as the quantity of air delivered is twice the normal at a given speed. Reciprocating compressors are generally best suited for medium pressure and volume applications. They are comparatively cheap, rugged in design, and have fairly high efficiencies. The disadvantages with this type, however, are the pulsating output and higher installation costs due to relatively high vibrations.

Screw air compressor

Rotary screw compressors have several advantages over reciprocating compressors. They are inherently more reliable and require less maintenance as they have few moving parts. Further, the maximum temperature anywhere in the compressor does not exceed 100 oC, thus obviating the need for cooling the casing. In screw compressors, the suction and

discharge valves are replaced by ports in the housing, and the piston is replaced by rotors. It consists of two helical rotors: an electric motor drives a rotor shaft, which in turn drives the other rotor. These compressors have less wear and tear and vibrations, and require smaller foundations. The advantages of a screw compressor are its smaller size, lighter weight, step-less capacity control, and less starting torque requirement. Also, the performance of screw compressors, unlike reciprocating and centrifugal compressors, is not affected by the presence of moisture in the suction air.

4.1.2 Performance assessment of compressed air system

Compressors are designed to deliver a fixed quantity of air at certain pressure. But, due to ageing, wear and tear or poor maintenance, compressor may not deliver the same volume of air as specified by the manufacturer in the nameplate. By performing the FAD (free air delivery) test, actual output of a compressor with reference to the inlet conditions can be assessed. The test determines the pumping capacity of the compressors in terms of FAD, i.e. air pumped at atmospheric conditions. Following tests are generally carried out for evaluating the operating capacity of compressors.

- i. Pump-up test
- ii. Suction velocity method

The pump-up test of a compressor needs isolation of the air receiver and compressor from rest of the plant, whereas the suction velocity method could be undertaken without isolating the compressor. Depending upon the operating conditions in the plant, suitable method is used to study the performance of the compressors. Apart from FAD, it is also advisable to check power consumption, the optimum pressure setting and carry out the air leak test in the air distribution network in the plant to evaluate the condition of the air distribution system. The methods of carrying these tests are explained below.

Measurement of FAD

Pump up test method

This test determines the pumping capacity of the compressors (reciprocating and screw) in terms of air pumped at atmospheric conditions. It requires the isolation of the air receiver from the system, and only the compressor, whose pumping capacity has to be determined, must be connected to it. The receiver must be drained before switching on the compressor. The time taken by the compressor to maintain the working pressure in the air receiver (compressor on time or on load time) must be observed. A minimum of three readings are required to calculate the average value of time. The volume of the pipeline between the compressor and the receiver must then be calculated. The capacity of the compressor can be calculated using the formula

$$FAD = \frac{(P_2 - P_1) \times V \times T_1}{P_1 \times t \times T_2}$$

Where,

FAD = actual pumping capacity of the compressor (m³/minute),

V = total volume (m^3) = $V' + v$,

V' = volume of the receiver (m^3),

v = volume of the pipe line connected from air compressor to air receiver (m^3),

P_1 = atmospheric pressure (1.013 bar absolute),

P_2 = final pressure of the receiver (bar absolute),

t = average time taken (minutes) $\frac{t_1 + t_2 + t_3}{3}$

t_1, t_2, t_3 = time taken to fill the receiver at working pressure of the system.

T_1 = inlet air temperature in K

T_2 = compressed air exit temperature in K

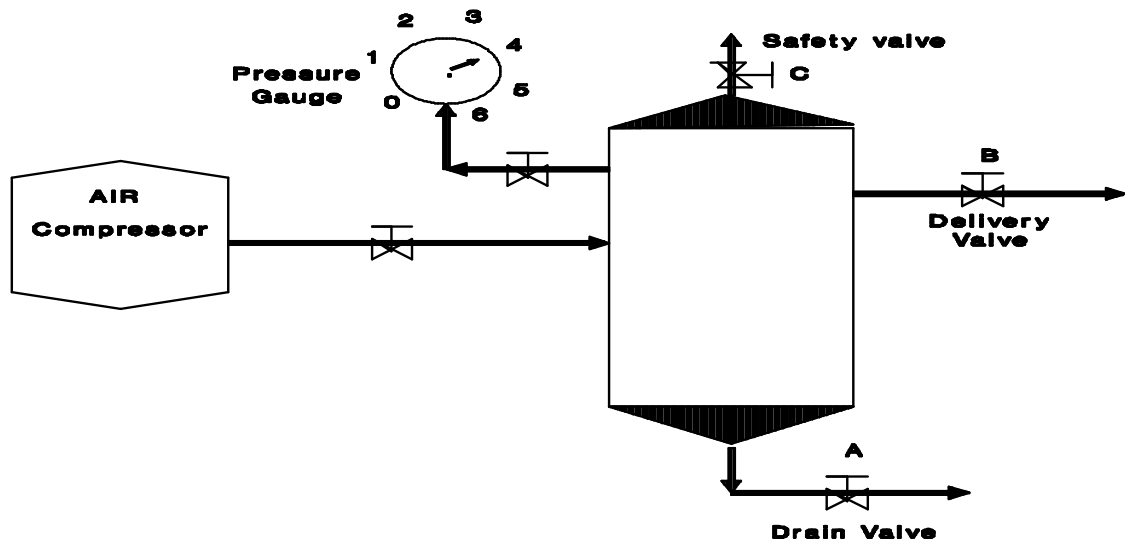

Figure 4.1.2a: Pump up test schematics

Suction velocity method

This methodology is only used wherever compressor cannot be isolated from the system. In this method, velocity of inlet air to the compressor is measured at the entire suction filters area with multiple readings using hand held portable instrument. Actual free air delivery for the compressors is calculated after averaging it out the multiple measurements of suction velocity and multiplying it with the net open area of the filter's suction area.

After calculating FAD either by pump up test or suction velocity method, compare the value with the design value of FAD. If the difference is more than 20%, it is important to check the piston rings, cylinder bores, and so on.

Specific power consumption

It is always better to evaluate the compressors on the basis of the specific power consumption index. This is the actual shaft power to generate 1 Nm³/minute (normal m³ per minute, that is, 1 m³ per minute at 1 bar, 0 °C and 0% RH) at 7 kg/cm² (g) or at any common pressure, when the compressor is running at full load. This ratio can be calculated

when the actual electrical power input (not the rated power of motor) and the FAD in Nm³/min are known.

$$\text{Specific power (kW/Nm}^3\text{/minute)} = \frac{\text{Actual power (kW)}}{\text{FAD (Nm}^3\text{/minute)}}$$

Pressure setting

The discharge pressure should be kept at the minimum required for the process or the operation of pneumatic equipment for a number of reasons, including minimizing the power consumption. The compressor capacity also varies inversely with discharge pressure and the power consumption increases (table 4.1.2a). Another disadvantage of higher discharge pressure is the increased loading on the compressor piston rods and their subsequent failure. Maintaining a higher air pressure (generated for buffer storage) than operating pressure is a waste of energy and cost. Also, at higher pressure, air leakages from the same size of orifice increase. An increase in operating pressure by 1 kg/cm² can increase energy consumption by four per cent. On the other hand, lower air pressure than required reduces the productivity of pneumatic tools drastically. Most of the air tools are designed to operate at 90 psig. The performance of these tools reduces by 1–4% for every one psig drop in pressure.

Table 4.1.2a: Power consumption of compressors at different pressures

Pressure (kg/cm ²)	Free air delivery (Nm ³ /min)	Shaft power (kW)	Specific power (kW/Nm ³ /min)
3	19.60	87.0	4.44
4	18.30	92.6	5.06
7	19.30	123.0	6.37
8	19.22	128.0	6.66
10	19.87	150.0	7.55

Leakage test

The leakage in the compressed air system can be quantified by running the compressor with all the air-using equipment shut off. The time taken for the system to attain the desired pressure or for the compressor to unload can be noted. This pressure will fall because of leakages in the system and the compressor will come on load again. The time taken for this to happen is to be noted as well. The period for which the compressor is on or off load should be recorded at least thrice to calculate an average value. The leakages can be estimated as follows.

$$L = \frac{(FAD) \times t_1}{t_1 + t_2}$$



Power wasted in Rs/year =

$$1.17 \times \text{Specific power consumption (kW/Nm}^3/\text{min)} \times L \times \text{operating hours/year} \times \text{Rs/kWh}$$

Where,

L = leakages (m³/minute)

FAD = actual free air delivery of the compressor (m³/minute)

t₁ = average on load time of compressor (second)

t₂ = average off load time of compressor (second)

A certain amount of wastage through leakage in any compressed system is inevitable, but air leakages above 5%, certainly needs in-depth study of the system. It is difficult to detect air leakages as they cannot be seen and smelt. While large leakages are easily detected by their hissing sound or by ultrasonic generated, it is difficult to detect small leakages, which can only be identified by applying soap solution on pipelines, joints, and so on. It is recommended that the entire distribution system be tested with soap solution once in six months. The air lost due to leakages can be quite significant depending on the air pressure. Table 4.1.2b gives the leakages through various orifice sizes and the resulting energy wastage at 7 kg/cm² air pressure.

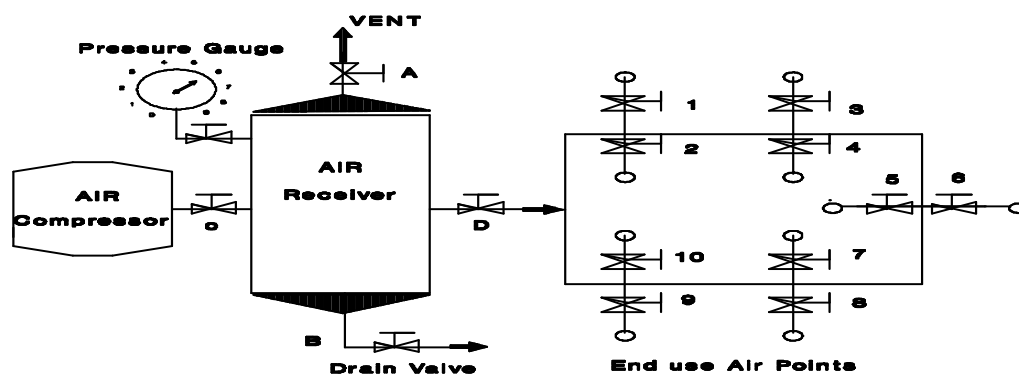

Figure 4.1.2b: Leakage test schematics

Table 4.1.2b: Power wastage from leakage of compressed air

Orifice diameter (inch)	Air leakage (Nm ³ /h)	Power wasted (kW)
1/64	0.721	0.08
1/32	2.88	0.31
1/16	11.53	1.26
1/8	46.20	5.04
1/4	184.78	20.19

Typical energy balance of the air compressor is shown in figure below:

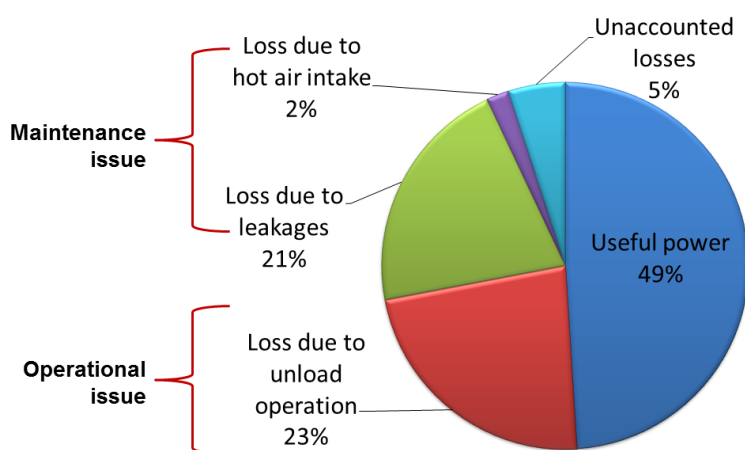

Figure 4.1.2c: Energy balance of air compressor

4.1.3 Replacement of in-efficient air compressor

EE compressor with VFD

Another foundry unit in Kolhapur foundry cluster manufactures and supplies CI and SG casting. The unit produces around 6000 metric tonne of casting per year. The corresponding annual energy consumption on that year was estimated to be around 493 toe costing 368 lakh rupees. The total CO₂ emission during the same period was estimated to be 5105 tonnes. The plant has two screw compressors for meeting the requirement of compressed air in the plant. Compressed air is mainly used to operate moulding machines, pneumatic grinders, mould cleaning and miscellaneous uses. The design specifications of existing compressors are given in table 4.1.3a.

Table 4.1.3a: Design details of existing compressors

Particular	Unit	Compressor 1	Compressor 2
Type		Screw	Screw
Operating mode		Load and unload	
Capacity	cfm	519.13	127.5
Pressure	kg/cm ²	7.6	7.6
Power	kW	75	30

Compressor 2 is a stand by system and 1 operates to meet plant requirement. Performance monitoring of the operating compressor was undertaken in detailed. Energy audit of the existing compressors in this unit revealed the possibilities of reducing energy consumption without disturbing compressed air requirement in the plant. The operating air compressor's motor has been re-wound thrice. The compressor was tripping many times while audit period. The power towards loading was 87kW. The specific energy consumption was measured 0.414kW/cfm while generating 210 cfm against design value of 520 cfm. The plant also admitted they are not able to meet full air requirement. Plant was having one 127.5 cfm air compressor in fairly good condition in other plant (not under use), it was recommended to run this for base load and install a new air compressor with VFD to meet variable load.

The VFD will minimize compressor unload power consumption as per quantity of compressed air requirement by optimizing speed of motor. The details of new VFD compressor are: Capacity: 225 cfm, power 37 kW and 7.1 bar. With recommendation and implementing support from energy auditing agency in the cluster, the unit benefitted by modifying the existing air compressor system with new VFD based screw compressor in the plant. Table 4.1.3b provides the detailed techno-economic analysis of the recommended EE project.

Table 4.1.3b: Details of recommended EE compressor

Actual Parameters	Unit	Value
Loading Pressure	kg/cm ²	5.9
Unloading Pressure	kg/cm ²	6.6
Specific Power Consumption	kW/cfm	0.414
Operational hours	hours/year	7,200
Base load Screw compressor		
Capacity	cfm	127.5
Pressure		7.6
Power	kW	30
Specific Power Consumption	kW/cfm	0.190
Annual energy consumption	kWh/year	1,74,420
Air compressor with VFD		
Capacity	cfm	225
Pressure	kg/cm ²	7.1
Power	kW	37
SPC	kW/cfm	0.180
Unload time per hour	Min	15.00
Saving per hour	kWh	3.13
Total Annual Energy Saving	kWh/year	1,08,930
CO ₂ avoided	tCO ₂ /year	96.95
Monetary saving	lakh INR/year	7.37
Investment cost	lakh INR	8.48
Simple payback period	Year	1.15

Down-sizing of existing screw air compressor

During normal operation, compressor in a foundry unit is operating in unloading condition for about 61% of the cycle. The specific energy consumption was calculated to be 0.277 kW/cfm. It is recommended to install new air compressor of lower capacity. It will serve two purpose vis-à-vis improve reliability, as old compressor will be as stand by and reduce power consumption. The design specifications of compressor are given in table 4.1.3c.

Table 4.1.3c: Design details of existing compressor

Particular	Unit	Compressor 1
Type and make		Screw & Atlas Copco
Operating mode		Load and unload
Capacity	cfm	127.5
Pressure	kg/cm ²	7.5

Power	kW	30
-------	----	----

The air compressor was loading for only 39% of time. The power consumption towards unload period was also high (14.3kW). It was recommended install a new air compressor of lower capacity. It would lead to reduced power consumption and will also improve reliability factor. The estimated annual energy savings in air compressor is 37,110 kWh equivalent to a monetary saving of Rs 2.60 lakh. The investment requirement is Rs 4.49 lakh with a simple payback period of 1.7 years. Cost benefit and saving estimation is given in table 4.1.3d.

Table 4.1.3d: Details of recommended on down-sizing of compressor

Actual Parameters	Unit	Value
Loading	%	39%
Unloading	%	61%
Loading	kW	30
Unloading	kW	14.30
Specific Power Consumption	kW/cfm	0.277
Hours of operation	hr/year	7200
Down-sizing of Air compressor	Unit	Air Compressor
Make		Kaeser ASD 32
Capacity	cfm	112
Pressure	kg/cm ²	7.5
Power	kW	18.5
SPC	kW/cfm	0.170
FAD Generated	cfm	108.381
Annual Energy Consumption	kWh/year	1,09,484
Annual energy saving	kWh/year	37,110
Monetary saving	lakh INR/year	2.60
Investment	lakh INR	4.49
Simple Payback	years	1.91
CO ₂ avoided	tCO ₂ /year	33.03

Replacement of reciprocating compressor by screw air compressor

During normal operation, in a foundry the reciprocating compressor is operating in unload position for above 52% of time. The power towards load time was 12.98 kW and that for unload period was 4.51 kW. The specific energy consumption of the air compressor was calculated to be 0.434 kW/cfm. The design specifications of existing compressor are given in table 4.1.3e.

Table 4.1.3e: Design details of existing compressor

Particular	Unit	Compressor 1
Type		Reciprocating
Operating mode		Load and unload
Capacity	cfm	34
Pressure	kg/cm ²	10
Power	kW	11

It is recommended to replace the air compressor with new screw air compressor. The specific energy consumption of the compressed air system will reduce. The specifications of recommended air compressor are: 57.2cfm, 7.5bar and 11kW. The estimated annual energy savings is 20,227 kWh equivalent to a monetary saving of Rs 1.46 lakh. The investment requirement is Rs 2.31 lakh with a simple payback period of 1.6 years. Cost benefit and saving estimation is given in table 4.1.3f.

Table 4.1.3f: Details of recommended on reciprocating to screw air compressor

Actual Parameters	Unit	Air Compressor
Loading	%	47.9%
Unloading	%	52.1%
Loading Pressure	kg/cm ²	7.5
Unloading Pressure	kg/cm ²	9.0
Loading	kW	12.98
Unloading	kW	4.51
Specific Power Consumption	kW/cfm	0.434
Hours of operation	hr/year	7200
New Screw Air Compressor	Unit	Air Compressor
Make		Atlas Copco
Model		GX-11-7.5P TM
Capacity	cfm	57.2
Pressure	kg/cm ²	7.5
Power	kW	11.0
SEC	kW/cfm	0.192
Generated CFM	cfm	29.92
Annual energy consumption	kWh/year	41,431
Energy savings	kWh/year	20,227
CO ₂ avoided	tCO ₂ /year	18.00
Monetary saving	lakh INR/year	1.46
Investment cost	lakh INR	2.31
SPP	year	1.59

4.1.4 Retrofits in compressed air system

Retrofit of VFD on screw air compressor

A foundry in Belgaum cluster equipped with 25 hp screw air compressor. During normal operation, compressor is operating in unload position for about 59% of time. The power towards load time was 21.9 kW and that for unload period was 7.7 kW. The specific energy consumption of the air compressor was calculated to be 0.202 kW/cfm. The design specifications of existing compressors are given in table 4.1.4a.

Table 4.1.4a: Design details of existing compressors

Particular	Unit	Compressor 1
Type and make		Screw & Atlas Copco

Operating mode		Load and unload
Capacity	cfm	114
Pressure	kg/cm ²	7.5
Power	kW	18

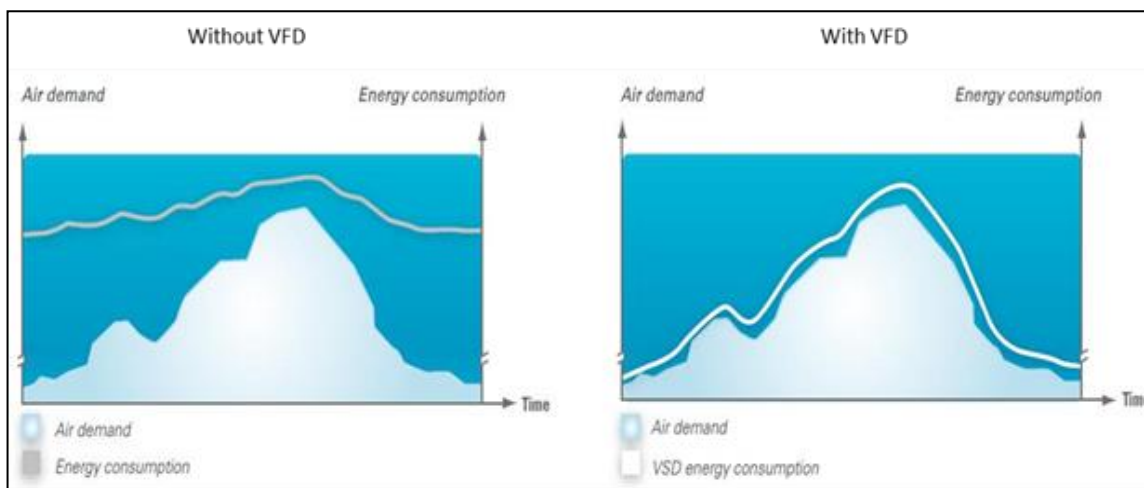

It is recommended to retrofit the air compressor with variable frequency drive (VFD) to minimize the unload power consumption. The VFD will minimize compressor unload power consumption as per quantity of compressed air requirement by optimizing speed of motor. It is recommended to load compressor around 85% of time. The estimated annual energy savings is 10816 kWh equivalent to a monetary saving of Rs 0.77 lakh. The investment requirement is Rs 1.24 lakh with a simple payback period of 1.6 years.

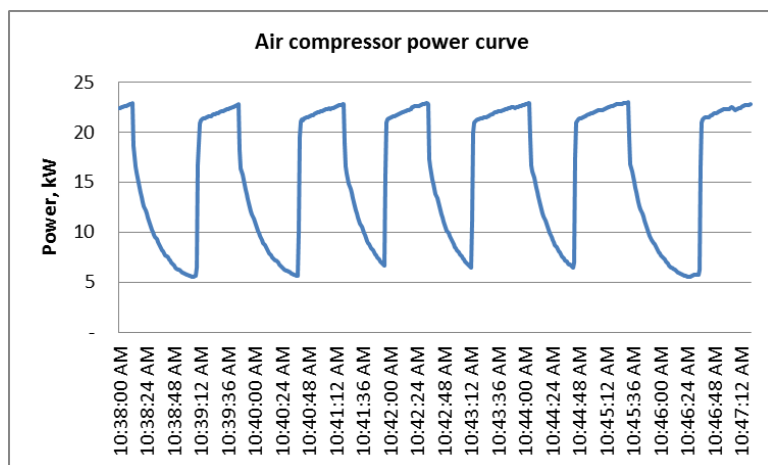

Table 4.1.4b: Details of VFD retrofitting on compressor

Actual Parameters	Unit	Value
Suction Area	cm ²	50.3
Suction Velocity	m/s	10.2
FAD Generated	m ³ /min	3.08
	cfm	108.6
Loading	%	41%
Unloading	%	59%

Loading pressure	bar	6.5
Unloading hours	bar	7.5
Loading	kW	21.9
Unloading	kW	7.7
Specific Power Consumption	kW/cfm	0.202
Operating hours	hour	3,600
VFD Retrofitting	Unit	Value
Unload power saving	%	15
Annual energy saving	kWh/year	10,816
	toe/year	0.93
Cost of electricity	INR/kWh	7.12
Monetary saving	lakh INR/year	0.77
Investment	lakh INR	1.24
SPP	year	1.6
CO ₂ avoided	tCO ₂ /year	9.6

Sequence controller for air compressors

A foundry in Rajkot was equipped with three screw type air compressors of rating 55 kW, 37 kW and 22 kW respectively. There was no control mechanism in place to insure proper meeting of the demand. The compressors were running in ad-hoc basis, leading to high energy consumption (1029 kWh per day).



It was recommended to install a sequence controller for the air compressors with closed loop feedback from a pressure transducer installed at the receiver end. This led to sequential operation of air compressor and led to improved energy performance. The daily energy consumption in compressed air system came down to 775 kWh. The switching between the air compressors with and without sequence controller for meeting foundry demand is shown in figure.

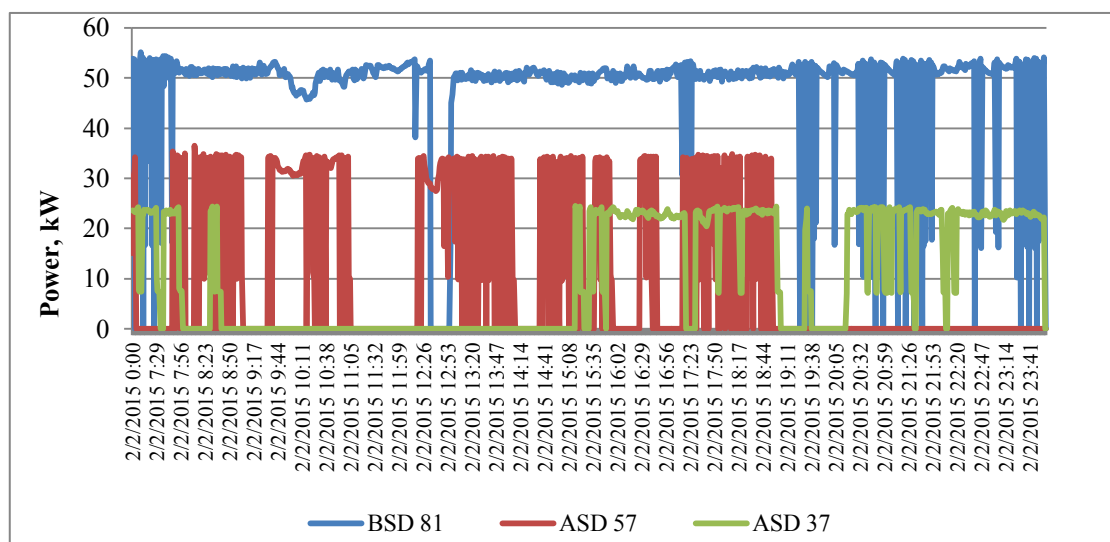

Figure 4.1.4a: Before sequence controller

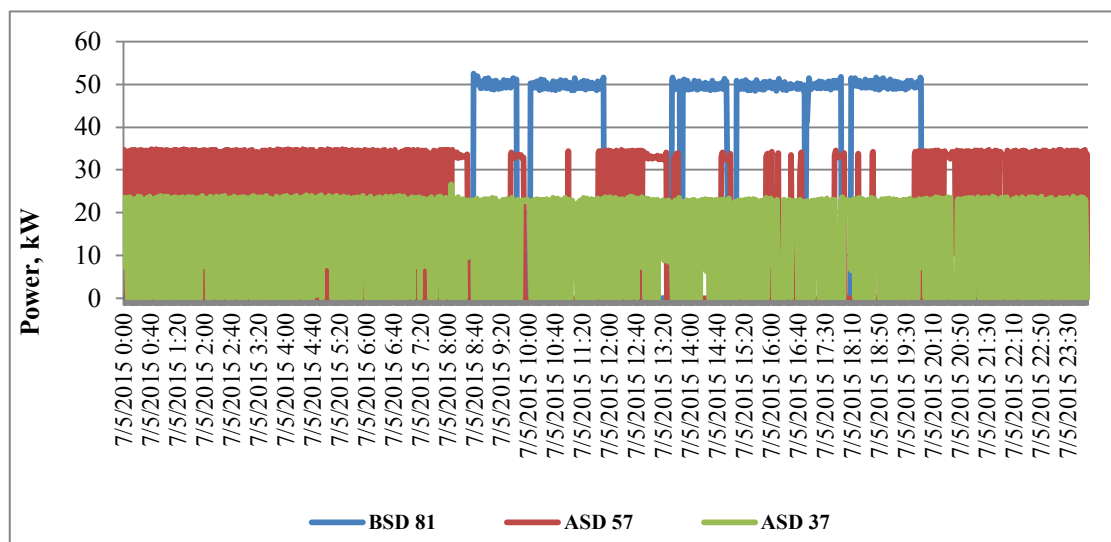

Figure 4.1.4b: After sequence controller

Compressed air network

Case study 1

A foundry in Howrah with annual production of about 3500 tonnes, was equipped with two screw type air compressors of 45 kW rating. The actual demand of the foundry was about 200 cfm of compressed air at 6 kg/cm² pressure. The plant was operating the air compressor at 9.6 kg/cm² pressure, owing to high level of losses in the compressed air network.

The compressed air piping around the moulding machine was found to have too many bends leading the loss of pressure. It was suggested to simplify the compressed air network and reduce the bends. The unit reduced the number of bends from four to two and brought down the compressor pressure by 0.8 kg/cm²; leading a direct energy saving of about 3.5%.

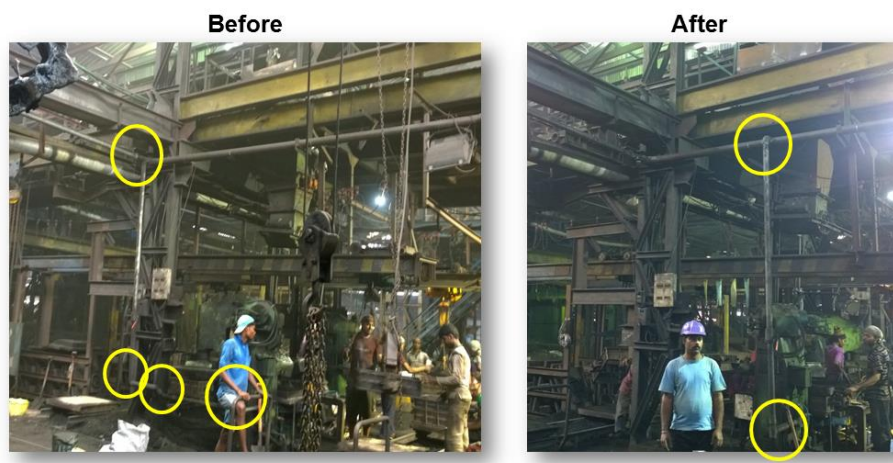

Case study 2

A foundry in Howrah with annual production of about 2550 tonnes, was equipped with two screw type air compressors of 55 kW rating, one of 22 kW rating and two 5hp in paint shop. The compressed air network of the unit is shown in figure. The foundry uses two 55 kW air compressor for meeting compressed air demand of the foundry section, whereas one 5 hp reciprocating compressor meets demand of paint shop along with tapping from centralized compressed air distribution network. The daily energy consumption is about 2304 kWh.

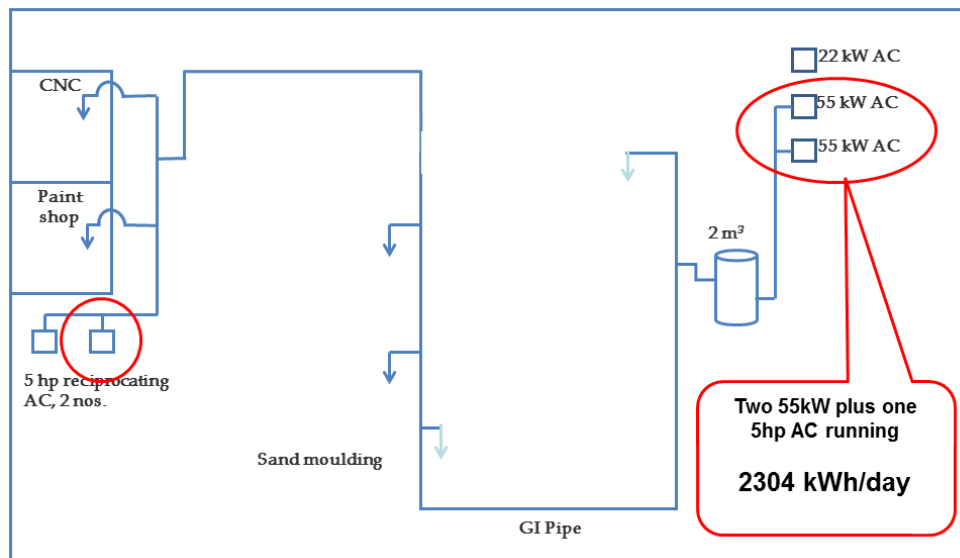

It was recommended to the unit to replace GI piping with seamless CPVC piping for compressed air distribution and make a ring main to reduce pressure drop in the line. The modified network is shown in the figure. The daily energy saving was about 469 kWh.

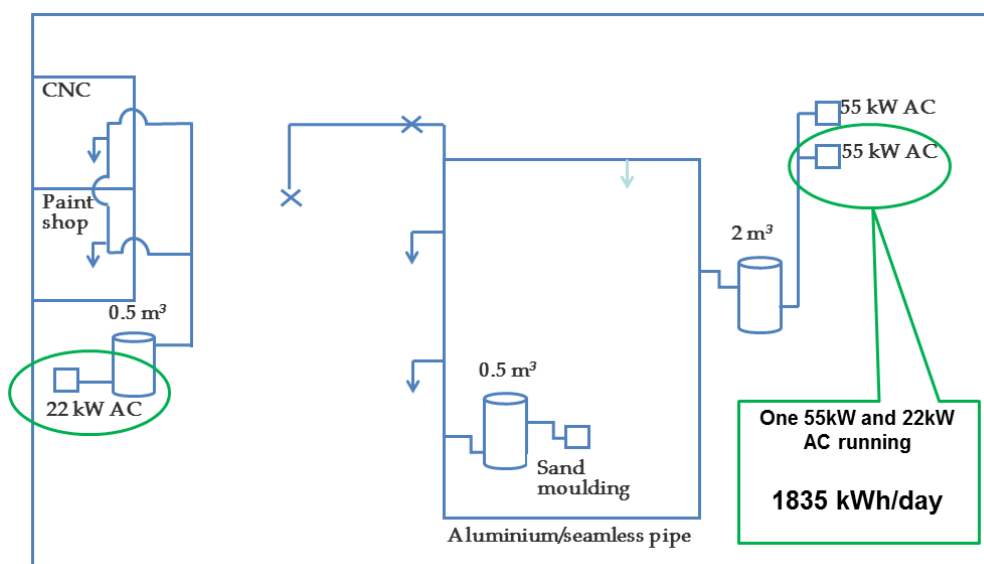

4.1.5 Best operating practices in compressed air system

Reduce the consumption of air

- There are always air leakages exists in the shop floor and which could be near to the equipment/application point and/or in the air piping distribution system

- Leakage test
 - ✓ Operate compressor at night, or holiday, and shut it down when achieving a predetermined pressure value.
 - ✓ When the compressor is shut down, due to the leakage, the pressure will automatically decrease. The amount of leakage can be known by measuring the time (T) taken to decrease the pressure by 1 bar.
 - ✓ Formula

$Q = \frac{(P1 - P2) \times V}{Po(1.033) \times T}$

 - ✓ Q=Volume of leakage (m³/min)
 - ✓ P1= Predetermined pressure (kg/cm²) (gauge pressure + 1.033kg/cm²)
 - ✓ P2= Pressure after leakage (kg/cm²) (gauge pressure + 1.033kg/cm²)
 - ✓ T=Time taken to reduce pressure from P1 to P2 (min)
 - ✓ Po= Atmospheric air pressure(kg/cm²)
 - ✓ V= Piping capacity (Mm³) (In case of your company; 72.31m³)
- There is a report that as much as 20% of leakage exists in a plant on average
- Since leakage directly leads to energy loss, it is the highest priority issue for air systems
- Be aware that leakage may occur anywhere.
 - ✓ Leakage from coupler
 - ✓ Leakage from pipe
 - ✓ Leakage from internal component of equipment
- For example, use of proper air nozzles for blowing will reduce the air consumption.
- So, reducing leakage is top-priority issue in air system.
- Recognizing that a leakage occurs from all places is required.
- The leakage with a sound is detected by using 'Leak Detector' e.g. Model-AAM-PWLEAK02
- However, cautions are required, since there is also the leakage with no sound.
- Leakage test can be carried out frequently to check the quantity of air leakages in the plant. The physical verification at joints of hoses, couplers will help to identify the air leakages, even soap solution can be poured at the joints for checking the air leakages.
- Leakage check test
 - ✓ Leakage check is performed at the night time or on holidays when the plant is not in operation.
 - ✓ Once the compressor is operated and raised up to predetermined pressure, then stop the compressor and measure the time required for pressure reduction of 1bar from the predetermined pressure.
 - ✓ Since all of this leads to waste of energy, there is a necessity for quick measures.
 - ✓ If in the above investigation, it is possible to calculate the amount of leakage, then leakage locations need to be identified in the next step.
 - ✓ As the amount of leakage can be calculated by the pressure drop calculation, after confirming the same the leakage areas can be identified and effective leakage reduction can be achieved.

- ✓ Target reduction is half of the total ratio.
- Keeping that in mind, take measures from the most leakage prone areas.
- Leakage cannot be completely stopped with the one-time measures.
- Continuous monitoring is required.

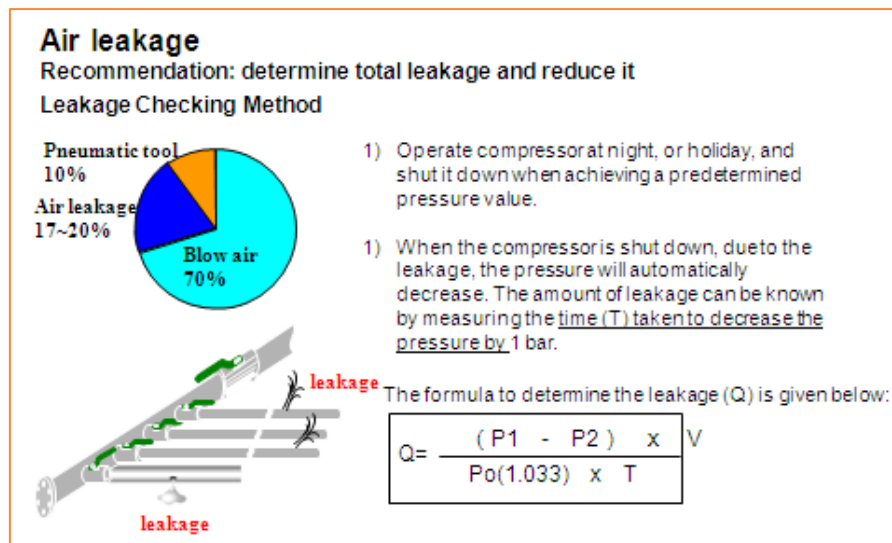

Figure 4.1.5a: Air leakage

Reduce air pressure and good air piping work

- There should be always pressure gauges installed in the air piping system for regular check of design and operating pressure of pressure gauges, if there is any fall in pressure for the existing set point of air compressor then there are huge leakages exists in the system and needs to identify the points



Figure 4.1.5b: Contents of Improvement Measures – Examination of Piping Work

- Increase pipe size to reduce pressure loss and important air piping work

- ✓ Piping system
 - How pressure loss changes if size changed?
 - How pressure loss changes if valve structure differs?
- ✓ Be sure to provide a drain connection for a riser pipe.
- ✓ Installation to a collecting pipe must be made from above to prevent backflow. (Similarly, branch pipes must be installed from above.)
- ✓ For a collecting pipe, give an inclination (1/100) from the upstream to the downstream. Attach a drain plug at the end of each pipe.
- ✓ Buried piping makes it difficult not only to detect air leakage but also to repair
- If there is need for higher pressure for particular application or process or shop then increase pressure by use of booster compressor instead of increasing set pressure of the entire air compressor system
- Pipe size - for reduced pressure loss without large no. of bends with 4 – 5 m/s of velocity, helps is load/unload of air compressor, running hours, leakages etc. Types of valves ball valves and globe valves, in globe valves there are 60% more losses than gate valves.
- Use of hosepipes increases the pressure drop. Piping should not be underground and drain valves should be placed at lower position in pipelines. The filter size should be adequate so, that there is no pressure drop. Higher resistance causes pressure drops and also there is overloading of the air compressors resulting in frequent breakdowns. Piping should be used in looping for reduced pressure drops.



Figure 4.1.5c: Examples of recommended piping

- If adequate and large receiver size is used, there is energy saving about 3%. Proper ventilation of air compressor decreases the surrounding temperature resulting in less stoppage due to over temperature and energy saving with less inlet temperature. For indirect ventilations large size fans are required. Proper layout of air duct is required for ventilation. For various air pressure requirements in the plant, pressure boosters or booster air compressors can be used, which will eliminate the high-pressure generation at main air compressor.

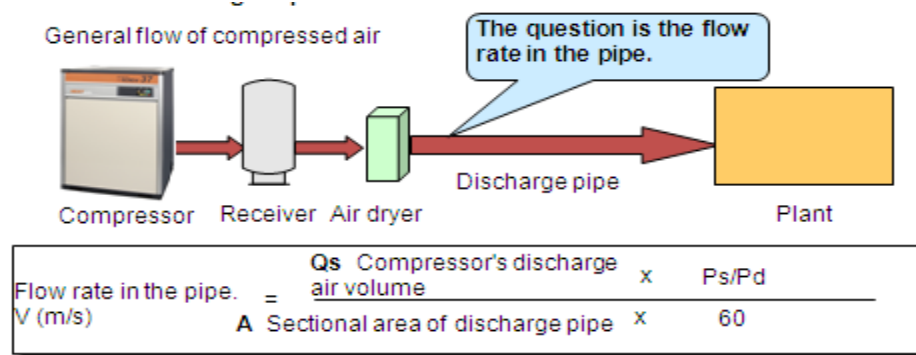

The flow rate in the pipe is desirably 4 to 5 m/s. - Economic speed

The smaller the pipe size, the higher the flow rate, causing a larger loss in the pipe. Accordingly an energy loss is generated, reducing energy-saving effect.

* Example of 75-kW HISCREW NEXT (Discharge pressure: 0.69 MPa, discharge air volume: 13.2 M³/min), size of discharge air pipe: 50mm
 $V = 13.2 \times 0.101 / (0.101 + 0.69) \div 0.05 \div 0.05 \div 3.14 / 4 \div 60$
 $= 14.31 \text{ m/sec}$ (This is a very high speed.) The energy-saving effect is low.

Figure 4.1.5d: Pressure loss through pipe and internal flow rate

Optimize the air compressor

- Pressure reduction by 1 bar will give energy saving of 6-8%.
- Air intake into the compressor room and better ventilation. (Pay attention to the gallery design - effective area)
 - ✓ Install the compressor in the direction so that a hermetically closed room or intake of contaminated air (oil, gas, etc.) is avoided.
 - ✓ Prevent the air discharged from the compressor room from being sent back into the room and circulating.
 - ✓ Discharge air in compressor room
 - ✓ Install the fan high on the wall of the compressor room.
 - ✓ When using a rain hood, take resistance into consideration when selecting a ventilating fan.
- Use of inverter type air compressors is important, as industry though are using inverter compressor are not getting desired energy savings. The continuous air compressor should be used at base load and inverter compressor should be used for variable load with proper pressure setting.

- Multiunit control can be used at the air compressor installations having more than 2 air compressors. Etc. He explained advantages/disadvantages of centralised and de-centralised air compressor systems.
- Plan/do/check/act is continuously required for energy efficiency requirement in compressed air system.

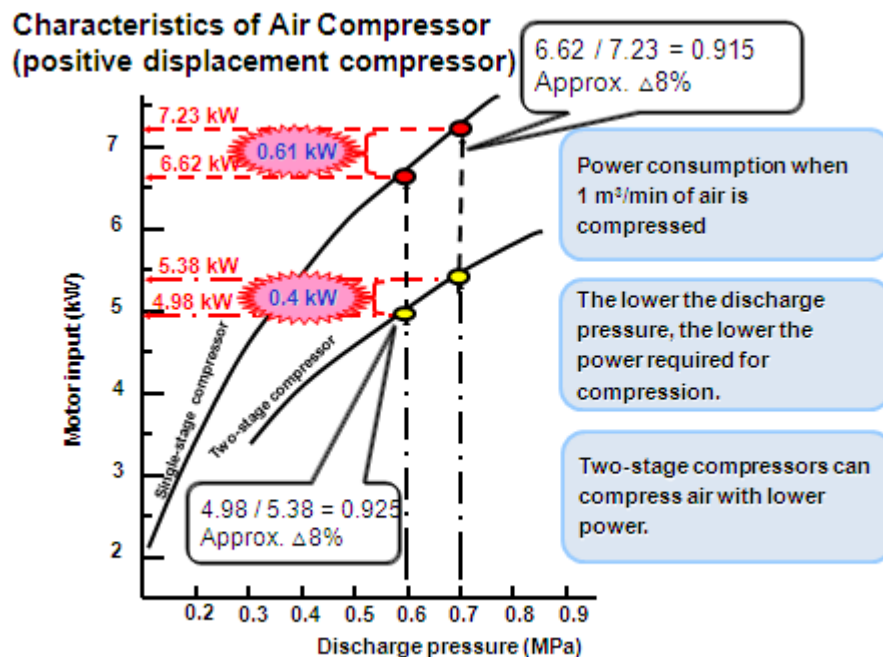

Figure 4.1.5e: Characteristics of air compressor

Some important points

- Life of air compressor in its life cycle is considered about 12 years life
- About pressure reduction ~6% saving is possible
- About centralized system, centralized system can be selected/ designed based on various factors like size, pressure and plant layout etc.
- About use of inverter type air compressor with percentage loading 50% to 90%, energy consumption cost savings of minimum 20% is possible even though there is less fluctuations in the compressor loading/unloading.
- About air receiver for high capacity air compressors, high capacity receiver could be used for Centrifugal air compressors which will give saving of 3 %.

Environment point in compressed air system

- Replacement of reciprocating air compressor and install low vibration, low noise level air compressors.

- Drain discharge according to the actual drain amount is required in order to efficiently avoid unnecessary damage to the environment and cost associated with generating process of compressed air.
- Intelligent electronic control system keeps the loss of compressed air and energy consumption to a minimum by BEKOMAT drain discharge equipped with capacity levelling sensor can be used for drain discharge.

Case study: Leakage loss

A foundry in Rajkot was able to bring down its compressed air leakages in the fettling shop by replacing the screw type connector of pneumatic line and the fettling machine with a aluminium crimping arrangement. This seals the pipe properly reducing the chances of leakages over the life of machine. The same is depicted in figure. The energy saving by reduction of compressed air leakages was in tune of 3 – 4%.

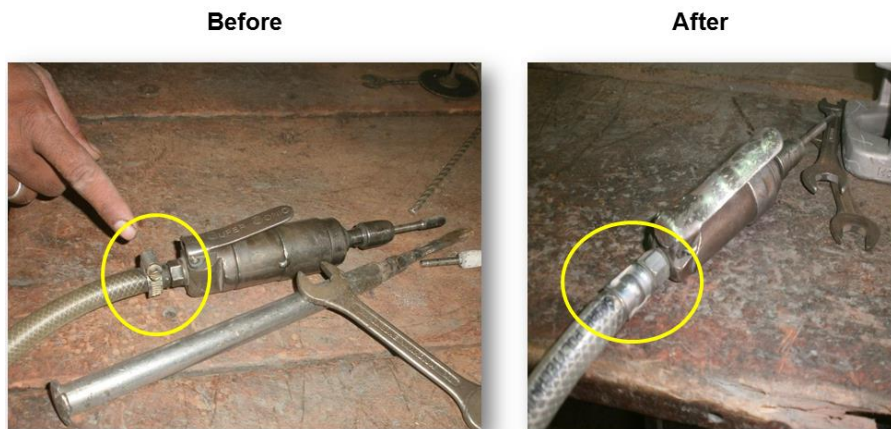

Case study: Cleaning of filter

A foundry in Howrah was using a 22 kW screw air compressor for meeting its compressed air demand. During study it was observed the filter was not cleaned for months. This led to an increase in specific power consumption of the air compressor by 2 kW per 100 cfm. The energy saving by proper cleaning of filter was in tune of 1 – 1.5%.



Case study: Exhaust duct for air compressor

A foundry in Kolhapur cluster was equipped with 30 kW air compressor to meet compressed air demand. The compressor was placed in a closed room thus leading to a higher temperature. The suction air temperature of the air compressor was about 5 °C higher than the ambient temperature. It was recommended to install an exhaust duct for the air compressor to throw the hot air outside the compressor room. This led to an energy saving in compressor of about 1%.



4.2 Cooling water system

4.2.1 Background

The foundry using induction furnace for melting have a dedicated cooling water circuit for meeting cooling demand of the coil and the also the power panel. The panel cooling and coil cooling is done using soft water i.e. demineralised water. A plate heat exchanger exchanges the heat from soft water to industrial raw water, which is circulated using another pump. Some foundry use this raw water pump to directly cool the water in a cooling tower, on the other hand a few units have hot well and cold well system, where another pump is incorporated for cooling tower water circulation.

Pump operating point

When a pump is installed in a system the effect can be illustrated graphically by superimposing pump and system curves. The operating point will always be where two curves intersect. Each centrifugal pump has a BEP at which its operating efficiency is highest and its radial bearing loads are lowest. At or near its BEP, a pump operates most cost effectively in terms of both energy efficiency and maintenance. In practical applications, operating a pump continuously at its BEP is not likely, because pumping systems usually have changing flow rate and system head requirements and demands. Selecting a pump with a BEP that is close to the system's normal operating range can result in significant operating cost savings.

The performance of a pump is typically described by a graph plotting the pressure generated by the pump (measured in terms of head) against flow rate. A performance curve for a typical centrifugal pump is shown in figure 4.2.1.

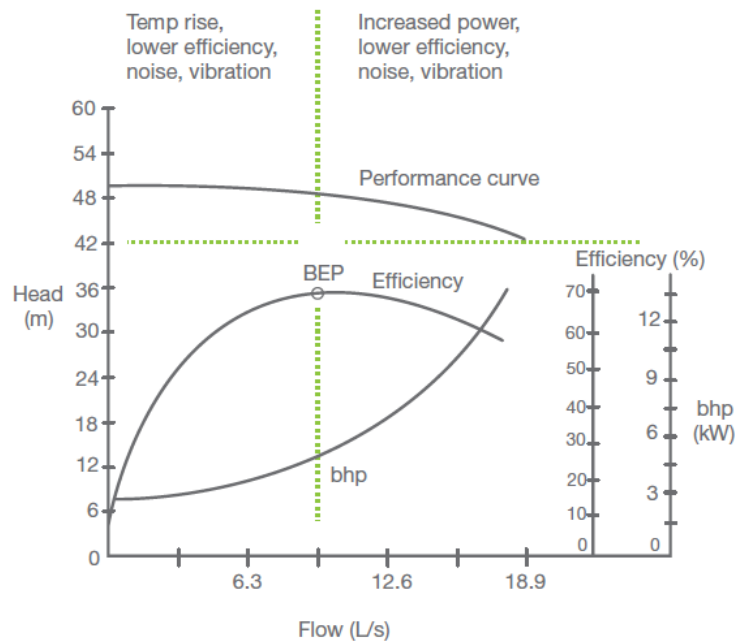

Figure 4.2.1: Pump operating point

If the actual system curve is different in reality to that calculated, the pump will operate at a flow and head different to that expected.

4.2.2 Performance assessment

Performance assessment of pumps

In metal casting industries, the pumps are mainly used to transfer water from reserve source point to user end as employed in the process and connected with the utilities to circulate the cooling water. The condition of an operating pump can be understood by calculating operating efficiency of the individual pump and comparing with design value. Efficiency of a pump can be estimated by the following relation.

$$\text{Hydraulic power} = \frac{Q \text{ (m}^3\text{/s)} \{ \text{total head (} h_d - h_s \} \text{ (m)} \times \rho \text{ (kg/m}^3\text{)} \times g \text{ (m/sec}^2\text{)}}{1000}$$

Where,

h_d – discharge head in metre, h_s – suction head in metre, ρ
– density of the fluid in (kg/m³), g – acceleration due to gravity.

Pump shaft power, P_s (kW) = Electrical input power (kW) × motor efficiency

$$\text{Pump Efficiency (\%)} = \frac{\text{Hydraulic power, } P_d \times 100}{\text{Pump shaft power, } P_s}$$

Best performance from a pump can be observed when a pump is operated at point where its operating curve intersects with system curve without any throttling at either stream of flow as shown in the figure 4.2.2a.

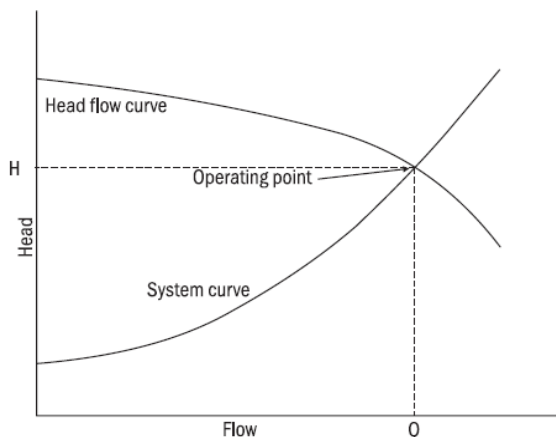

Figure 4.2.2a: Operating curve of a Pump

The pump performance will vary depending upon the operating parameters like RPM (N), input power (kW), head (H) and flow rate (Q). These operating parameters are linked with the following relationship.

Flow: Flow is proportional to speed; $\frac{Q_1}{Q_2} = \frac{N_1}{N_2}$

Where, Q_1 is flow corresponding to speed N_1 and Q_2 is the flow corresponding to speed N_2

Head: Head is proportional to the square of speed; $\frac{H_1}{H_2} = \frac{(N_1)^2}{(N_2)^2}$

Power (kW): Power is proportional to the cube of speed; $\frac{kW_1}{kW_2} = \frac{(N_1)^3}{(N_2)^3}$

As can be seen from the above laws, doubling the speed of the centrifugal pump will increase the power consumption by eight times. Conversely a small reduction in speed will result in drastic reduction in power consumption. This forms the basis for energy conservation in centrifugal pumps with varying flow requirements. The table 4.2.2a provides the list of data that are required for calculating above mentioned performance indicators of a cooling tower.

Table 4.2.2a: List of operating parameters of pump

S No	Parameter
1	Power consumption (kW)
2	Suction head (metre)
3	Delivery head (metre)
4	Pump flow rate (kg/second)
5	Fluid temperature (°C)

Performance assessment of cooling tower

Cooling towers are mainly used in foundries to circulate cooling water to user end in the process to meet the desire requirement in the plant. It could be either natural draught or forced draught operation. Figure 4.2.2b shows the simple schematic view of water and air flow to a cooling tower.

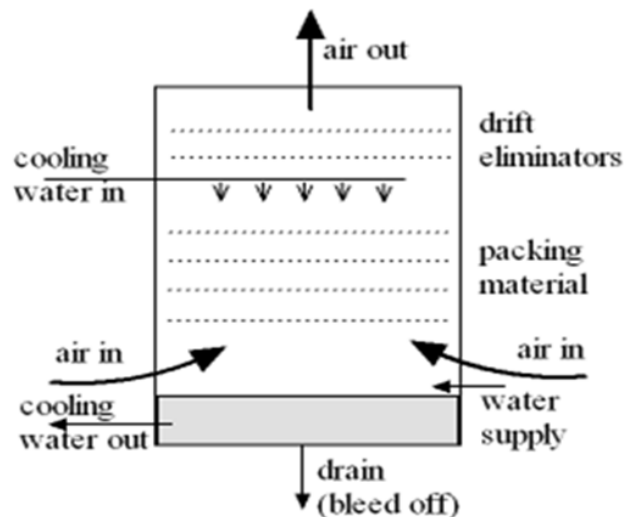
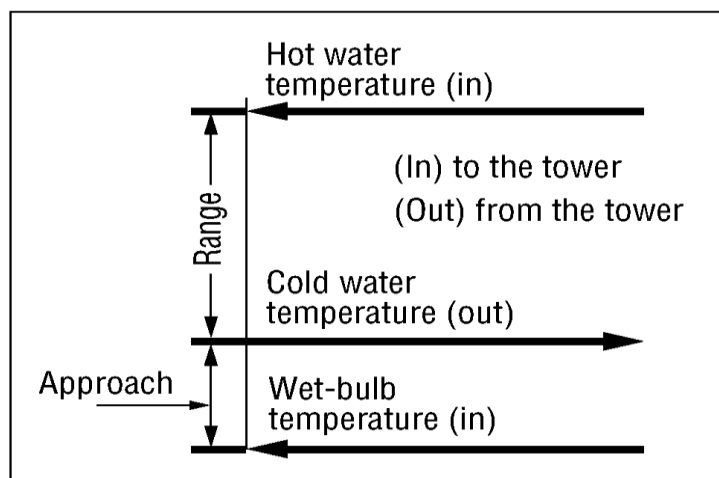

Figure 4.2.2b: Schematic view of cooling tower

The performance of cooling tower can be compared with the rated output with the actual output like range, approach, effectiveness, heat rejection capacity in TR, evaporation loss and make up water flow rate etc. Cooling duty water flow rate and its temperature helps to estimated difference performance of cooling tower. Some of the important performance indicators of cooling tower are represented in figure 4.2.2c. The relation to estimate range, approach and effectiveness for a given cooling tower are mentioned below:

$$\text{Range} = \text{Entering cooling water temperature (return from process)} \\ - \text{Leaving water temperature (supply to process)}$$

$$\text{Approach} = \text{Leaving cooling water temperature} - \text{Ambient wet bulb temperature}$$



$$\text{Effectiveness} = \frac{\text{Range}}{(\text{Range} + \text{Approach})}$$

Figure 4.2.2c: Representation of cooling tower performance indicators

Heat rejected or cooling capacity; TR

$$TR = \frac{(\text{mass of flow rate} \times \text{specific heat} \times \text{range})}{3024}$$

$$= \frac{(1000 \times \text{flow (m}^3/\text{h)}) \times \text{cooling tower inlet and outlet temperature difference (T)}}{3024}$$

Evaporation loss is the water quantity evaporated for cooling duty; as a thumb of rule for every 1 million of kcal heat rejected, the evaporation quantity could be worked out at 1.8 m³

Blow down losses depend upon COC (cycles of concentration), where COC is the ratio of dissolved solids in circulating water to the dissolved solids in make-up water. The total make up water quantity is depended on the loss of circulating water in drift, evaporation and blow down.

Make up water quantity = drift loss + evaporation loss + blow down loss

The data required to be collected form cooling tower system for evaluating its performance are given below.

Table 4.2.2b: list of operating parameters of cooling tower system

S No	Parameter
1	Ambient dry bulb temperature (°C)
2	Ambient wet bulb temperature (°C)
3	Average Cooling water inlet temperature (°C)
4	Average Cooling water outlet temperature (°C)
5	Average Cooling duty water flow rate (m ³ /hour)

4.2.3 Energy efficiency in pumps

Case study

In a foundry unit monthly production of 121 tonnes was equipped with a 500 kg, 350 kW induction furnace. The coil cooling pump of the furnace was mono-block type with 34% rated efficiency. The power consumption of furnace coil cooling pump was measured to be 4.5 kW. The water flow rate was measured to be 10.8 m³/hr which is lower than the design flow of 14.4 m³/hr. The overall efficiency of the pump is calculated to be 26% which is lower than design efficiency (34%).

The performance of an induction furnace is directly linked with the performance of its cooling water circuit. Therefore, it is recommended to replace the existing furnace coil cooling pump with an energy efficient pump. The cost benefit analysis of the EE pump is shown in table.

Table 4.2.3: Replacement of existing coil cooling pump with energy efficient pumps

Recommended Pump Specification	Units	Coil cooling pump for Furnace
Flow rate	m ³ /hour	14.4
Differential Head	m	40.0

Efficiency	%	51.1%
Power proposed pump	kW	3.07
Power saving	kW	1.43
Operating period	hour	4,800
Annual Energy saving	kWh/year	6,856
Cost saving		
Annual Monetary Saving	Rs lakh / year	0.42
Investment	Rs lakh	0.55
Simple Payback Period	years	1.3
CO ₂ emission avoided	tCO ₂ /year	6.7

The estimated annual energy savings in coil cooling pump is 6,856 kWh equivalent to a monetary saving of Rs 0.42 lakh. The investment requirement is Rs 0.55 lakh with a simple payback period of 1.3 years. The annual reduction in CO₂ emission is estimated to be 6.7 tCO₂.

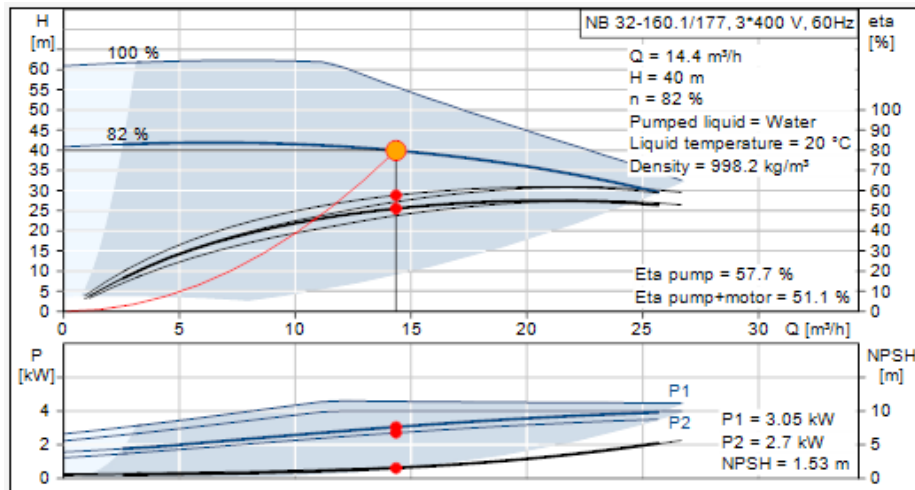

Figure 4.2.3: Proposed coil cooling pump

4.2.4 Energy efficiency in cooling tower

CASE STUDY: FRP Blades

The existing cooling tower in a foundry incorporates induced axial flow fans with aluminium blades. It is well known that aluminium blades are heavier and need comparatively greater starting torque. The measured power of fan was 4.0 kW.

It is recommended to change the cooling tower fan blades from Aluminium to Fibre reinforced plastic. Usage of FRP blades instead of aluminium blades generates 20% savings. The metal blades in cooling



tower fan can be replaced with 'fibre reinforced plastic' (FRP) blades, which are lighter. Use of FRP blades would reduce the power consumption of cooling tower system. It further increases the possibility of de-rating or re-sizing the motor capacity of cooling tower fan to a lower sized motor. The other advantages of FRP blade include high reliability and better performance due to lower failure rate.

The annual energy savings potential is 5,760 kWh equivalent to a monetary saving of Rs 0.45 lakh. The investment requirement is Rs 0.20 lakh with a simple payback period of 0.4 year.

Table 4.2.4: Replacement of existing coil cooling pump with energy efficient pumps

Fan power	kW	4.00
Replace Al blade by FRP blade		
Reduction in power by FRP	kW	0.80
Energy Saving	kWh/year	5,760
	toe/year	0.50
Energy cost	INR/kWh	7.89
Monetary Saving	lakh INR/year	0.45
CO ₂ emission reduction	tCO ₂ /year	5.13
Investment	lakh INR	0.20
SPP	years	0.44

CASE STUDY: Thermostatic controller

The main function of a cooling tower is to reduce the temperature of incoming water based on wet bulb temperature and relative humidity of ambient conditions. A majority of the cooling towers are not equipped with automatic controls to regulate the fan operation. A few units control the cooling tower operations manually based on outlet temperatures of cooling water. The seasonal variations in ambient temperatures and relative humidity show that the cooling tower requires continuous monitoring of temperatures for effective operation. The maximum possible drop in temperature of cooling water is limited to the wet bulb temperature of the ambient conditions.

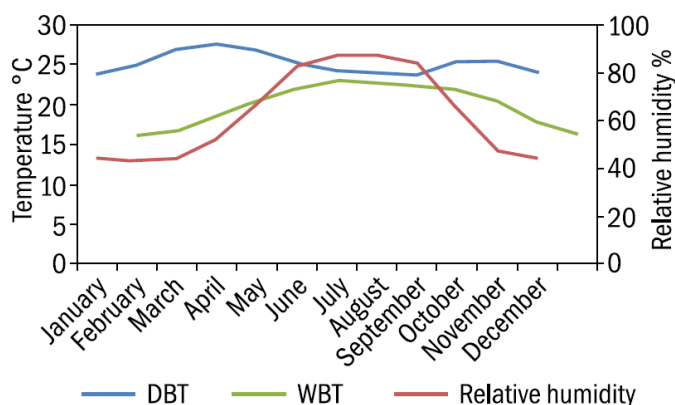

In place of manual operation, automatic controls are preferred. The most common system used in cooling towers is thermostatic controller. It senses the outlet temperature of the cooling water. The controller switches-on or off the fan automatically based on prevailing level of cooling water temperature.

The typical energy savings with installation of thermostatic controllers in cooling water circuit is about 5–10% depending on geographical location. Typically for a cooling tower the energy saving is in tune of 0.1 kWh per tonne of liquid metal.

4.2.5 Best operating practices in cooling water circuit

Indication that pumps is oversized

Following table enlists the characteristics of an oversized pump and its reasoning:

Characteristics of an Oversized Pump	Description
Excessive flow noise	Oversized pumps cause flow-induced pipe vibrations, resulting in excessive noise and increased damage to pipework (including flanged connections, welds and piping supports)
Highly throttled flow control valves	Pumps tend to remain in more restrictive positions in systems with oversized pumps; this increases backpressure, further decreasing efficiency
Frequent replacement of bearings and seals	Increased backpressures from increased flow rates creates high radial and thrust bearing loads as well as high pressures on packing glands and mechanical seals
Heavy use of bypass lines	A system that heavily uses bypass lines indicates that the system has either Oversized pumps, is not balancing properly, or both
Intermittent pump operation	Pumps being used for purposes such as filling or emptying tanks that run very Intermittently indicate oversizing and hence suffer increased start/stop inefficiencies And wear, as well as increased piping friction

Pump wear and maintenance

Effective, regular pump maintenance keeps pumps operating efficiently and allows for early detection of problems in time to schedule repairs and to avoid early pump failures. Regular maintenance avoids losses in efficiency and capacity, which can occur long before a pump fails.

The main cause of wear and corrosion is high concentrations of particulates and low pH values. Wear can create a drop in wire to water efficiency of unmaintained pumps by around 10–12.5%. Much of the wear occurs in the first few years, until clearances become similar in magnitude to the abrading particulates. Referring to Figure 4.2.5, it can be seen that it tends to level out after 10 years. Catastrophic failure can occur around 20 years.

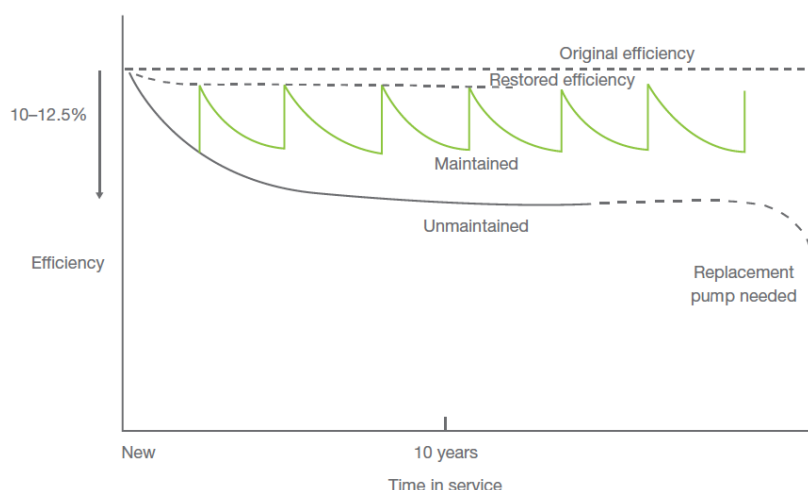

Figure 4.2.5: Average wear trends for maintained and unmaintained pumps

Common problems and measures to improve efficiency

Studies indicate that the average pumping efficiency in manufacturing plants can be less than 40%, with 10% of pumps operating below 10% efficiency. Oversized pumps and the use of throttled valves were identified as the two major contributors to the loss of efficiency. Energy savings in pumping systems of between 30% and 50% could be realized through equipment or control system changes. A pump’s efficiency can also degrade during normal operation due to wear by as much as 10% to 25% before it is replaced.

Common Problem	Potential Measures to Improve Efficiency
Unnecessary demand on pumping system	Reduce demand on system
Oversized pumps	Select pump that operates near to BEP Change impeller Trim impeller Fit multiple-speed pump Use multiple-pump arrangements Fit lower speed pump/motor
Pump wear	Pump maintenance
Less efficient impeller	Change impeller
Inefficient pump throttling controls	As for oversized pumps Fit adjustable or variable-speed drive
Inefficient piping configuration	Change piping inefficiencies
Oversized motor	Change motor
Inefficient motor	Change to high-efficiency motor
Lack of monitoring and/or documentation	Install monitoring and conduct survey

Best operating practises summary

- Ensure adequate NPSH at site of installation.
- Ensure availability of basic instruments at pumps like pressure gauges, flow meters.

- Operate pumps near best efficiency point.
- Modify pumping system and pumps losses to minimize throttling.
- Adapt to wide load variation with variable speed drives or sequence control of multiple units.
- Stop running multiple pumps -add an auto-start for an on-line spare or add a booster pump in the problem area.
- Use booster pumps for small loads requiring higher pressures.
- Increase fluid temperature to reduce pumping rates in case of heat exchangers.
- Repair seals and packing to minimize water loss by dripping
- Balance the system flows and reduce pump power requirements
- Avoid pumping head with a free return (gravity): Use siphone effect to advantage
- Conduct water balance consumption
- Avoid cooling water re-circulation in DG sets , air compressors, refrigeration systems, cooling towers feed water pumps, condenser pumps and process pumps.
- In multiple pump operations, carefully the operation of pumps to avoid throttling
- Provide booster pumps for few areas of higher head
- Replace od pumps by energy efficient pumps
- In case of over designed pump, provide variable speed drive, or downsize/replace impeller or replace with correct sized pump for efficient operation
- Optimize number of stages in multi-stage pump in case of head margins
- Reduce system resistance by pressure drop assessment and pipe size optimization

List of references

- Bureau of Energy Efficiency Guide Books – Compressed air system
- Bureau of Energy Efficiency Guide Books – Pumps and pumping system
- Bureau of Energy Efficiency Guide Books – Cooling tower
- TERI – Past studies on foundries