

Comprehensive training material for EE/RE system suppliers Khurja ceramic cluster

GEF-UNIDO-BEE Project

Promoting Energy Efficiency and Renewable Energy in selected MSME clusters in India

Prepared for:



Bureau of Energy Efficiency

©Bureau of Energy Efficiency, 2018

This document has been originally prepared by TERI as a part of 'Capacity Building of LSPs' activity under the GEF-UNIDO-BEE project 'Promoting Energy Efficiency and Renewable Energy in selected MSME clusters in India'.

Suggested Format for Citation

This document may be reproduced in whole or in part and in any form for educational and non-profit purposes without special permission, provided acknowledgement of the source is made. BEE and TERI would appreciate receiving a copy of any publication that uses this document as a source. A suggested format for citation may be as below:

GEF-UNIDO-BEE Project, Bureau of Energy Efficiency, 2018

“Capacity Building of Local Service Providers”

For more information

GEF-UNIDO-BEE PMU

Bureau of Energy Efficiency

4th Floor, Sewa Bhawan, Sector-1,

R.K. Puram, New Delhi-110066

Email: gubpmu@beenet.in

pmc@teri.res.in

Website: www.beeindia.gov.in

www.teriin.org

Disclaimer

This document is an output of an exercise undertaken by TERI under the GEF-UNIDO-BEE project's initiative for the benefit of MSME units and is primarily intended to assist the decision making by the management of the intended unit for

the proposed technology. While every effort has been made to avoid any mistakes or omissions, GEF, UNIDO, BEE or TERI would not be in any way liable to any person or unit or other entity by reason of any mistake/omission in the document or any decision made upon relying on this document

Contents

About this manual.....	1
1.0 Introduction.....	1
1.1 Background	1
2.0 Module 1 - Energy conservation opportunities in ceramic units	3
2.1 Fundamentals of gas based combustion systems	3
2.2 Energy efficient and renewable energy technology options	7
2.3 Best operating practices in a pottery unit.....	8
2.4 Fault diagnosis and trouble shooting	11
3.0 Module 2 - Advanced technologies for pottery industries	19
3.1 Background	19
3.2 Advanced technological options for pottery industries	19
List of references	31
4.0 Module 3 - Financing schemes and DPR preparation for EE projects.....	33
4.1 Introduction.....	33
4.2 Major financial schemes for MSMEs in India.....	36
4.3 Various credit lines and bank schemes for financing of EE	38
4.4 Preparation of detailed project report (DPR)	39
4.5 Step by step approach for loan application.....	41

About this manual

This manual provides, in a direct and simple manner, guidance on improving energy efficiency for local service providers (LSPs) in the 'EE/RE system suppliers' category.

The aim is to build their capacities and equip them with the necessary knowledge and skills and to provide background information and tips regards energy efficiency (EE)/renewable energy (RE) options in important ceramic manufacturing process viz. energy conservation opportunities in ceramic units and advanced technologies for ceramic industries. A separate module on Financing schemes and DPR preparation for EE projects has been added to build the capacities of LSPs on preparation of bankable DPRs.

The manual is designed to complement the knowledge shared with the participants through a series of four one day training/capacity building programs undertaken by TERI in Khurja Ceramic Cluster between February to April 2018 under the GEF-UNIDO-BEE Project "Capacity Building of Local Service Providers".

1.0 Introduction

1.1 Background

The overall aim of the GEF-UNIDO-BEE project is to develop and promote a market environment for introducing energy efficiency and enhancing the use of renewable energy technologies in process applications in selected energy-intensive MSME clusters in India. This would help in improving the productivity and competitiveness of the MSME units, as well as in reducing the overall carbon emissions and improving the local environment.

The following three ceramic clusters are targeted under the assignment - Thangadh, Morbi and Khurja.

This comprehensive training material for Khurja ceramic cluster is targeted at 'EE/RE system suppliers' category. The material is structured in the following 3 modules.

Module 1	Energy conservation opportunities in ceramic units
Module 2	Advanced technologies for ceramic industries
Module 3	Financing schemes and DPR preparation for EE projects

2.0 Module 1 – Energy conservation opportunities in ceramic units

2.1 Fundamentals of gas based combustion systems

2.1.1 Combustion of fuel

Combustion is a chemical process that converts chemical energy to thermal energy. There are three types of combustion:

- *Perfect combustion* is achieved when all the fuel is burnt using only the theoretical amount of air, but perfect combustion cannot be achieved in actual operating conditions
- *Complete combustion* is achieved when all the fuel is burnt using the minimal amount of air above the theoretical limit. Complete combustion should be the goal. With complete combustion, the fuel is burned at the highest combustion efficiency with low pollution.
- *Incomplete combustion* occurs when all the fuel is not burnt, which results in the formation of unburnts such as carbon monoxide and soot.

During combustion, heat energy is released due to oxidation of fuel composition depending upon the type of combustion takes place. The quantity of energy released from fuel constitute depends on type combustion product generated during oxidation.

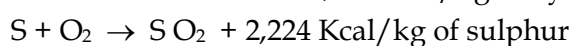
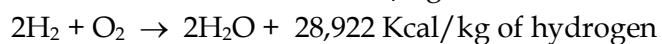
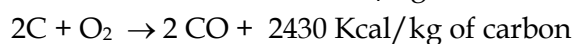
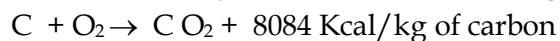

2.1.2 Excess air for combustion

The theoretical air to fuel ratio for complete combustion of the fuel is known as stoichiometric air-fuel ratio. If the quantity of air is less than the stoichiometric, the air-fuel mixture is known as 'rich mixture' and in case air is more than the stoichiometric, the air-fuel mixture is known as 'lean mixture'. The amount of air that is supplied more than the theoretical requirements to ensure complete combustion is referred to as the 'excess air'. The level of excess air is dependent on the type of fuels and their composition, which is shown below.

Fuel type	Excess air (%)
Solid fuels	25 – 60
Liquid fuels	15 – 35
Gaseous fuels	10 - 20

2.1.3 Gas based kiln system

The important components of a gas based kiln are air train and gas train. The air train comprises ID/FD fans, control valves, heat recovery systems (WHR), bypass lines, etc. The gas train comprises gas meter, filter, pressure regulator, non-return valve, pressure gauge, pressure switch, burner, etc. A typical schematic view of air train and gas train are shown below.

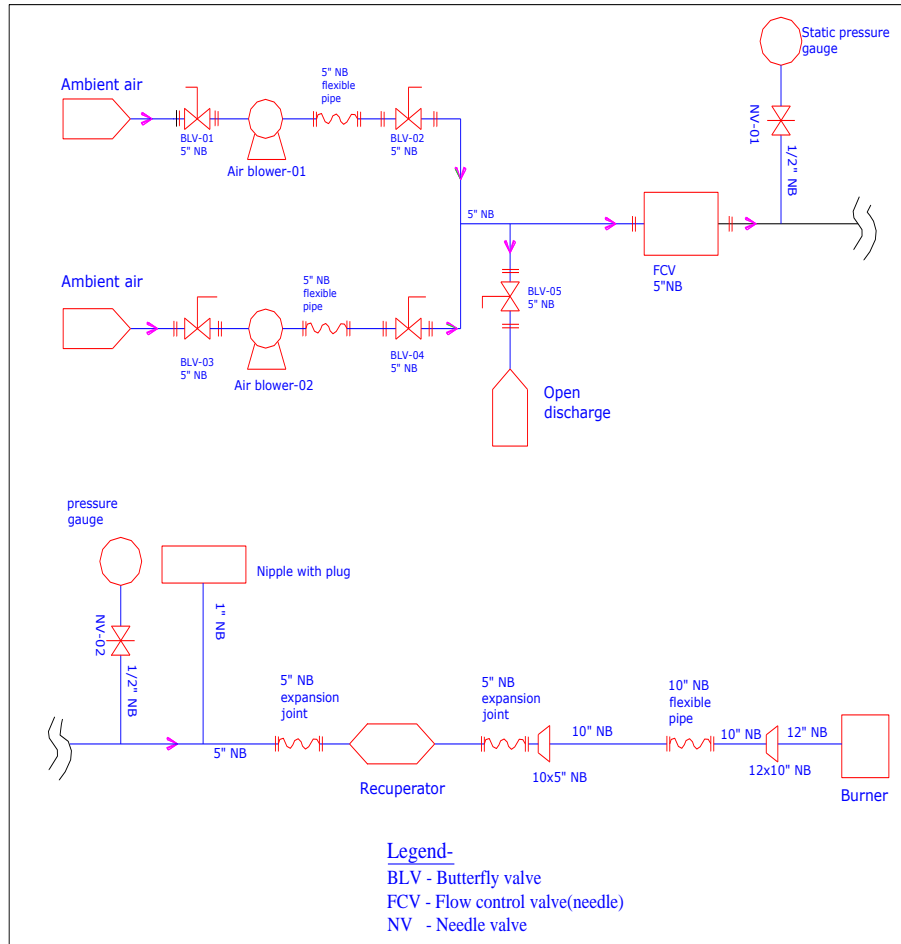

Gas train

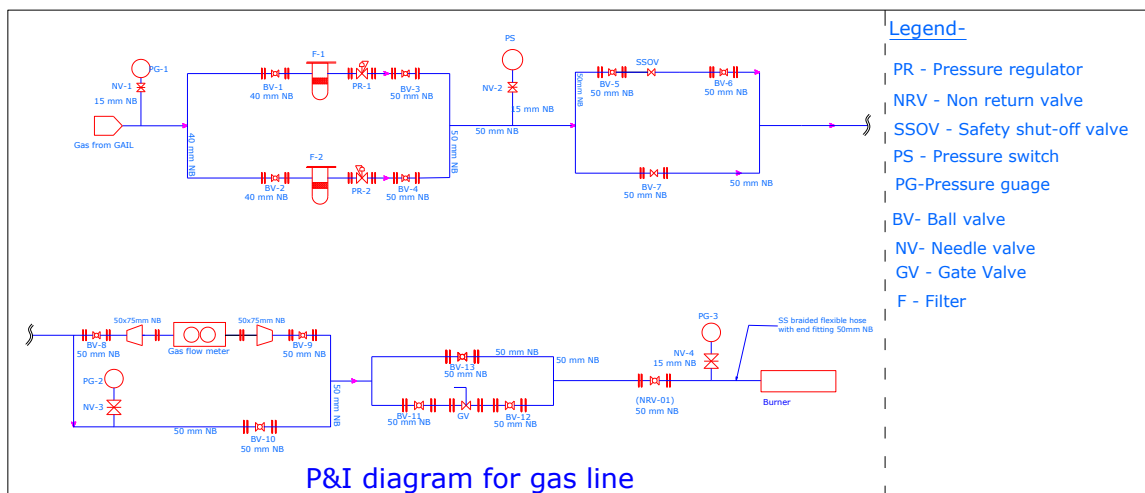

P&I diagram for gas line

Air train

2.1.4 Draft system

The purpose of providing a draft system is to exhaust the products of combustion from the furnace into atmosphere after effectively recovering the heat. Different types of draft systems used are briefed below.

- Natural draft system is produced using chimney
- Mechanical draft system
 - Induced draft system draws sufficient draught for flow into the furnace using a fan
 - Forced draft system uses a fan to force combustion products to flow through the system
 - Balanced draft system uses both induced draft and forced draft systems

2.1.5 Combustion controls

Combustion controls assist the burner in regulation of fuel supply, air supply, maintaining air-fuel ratio and removal of flue gases in an effective manner to achieve optimum thermal efficiency. The fuel firing rate must be in line with the production level in the furnace. The combustion controls are necessary as safety systems to ensure safety operation of furnace system. Different control systems used in combustion system include the following.

- *On-off control*: In this, the burner is on at full firing rate or switched off when not required.
- *High-low-off control*: The burner can operate at full firing or low firing depending on load requirements
- *Modulating control*: This operates on the principle of matching furnace load by altering firing rate on the entire operating range. It controls combustion air supply as well as fuel supply to the burner.

Any ineffectiveness in generation of heat from fuels will affect the overall performance

The industry has to follow 3-R principle - Reduce, Recover and Recycle to reduce fuel consumption.

Every 22 °C reduction in flue gas temperature or preheating combustion air by 20 °C leads to 1% fuel saving

Regular maintenance and cleaning of WHR system to be scheduled when the preheat temperature drops by 50 °C

2.1.6 Instrumentation of firing kiln

The important instruments that will be useful for monitoring and recording the key parameters to assess the performance of the kiln are provided below.

Instrument	Purpose
Gas flow meter	Gas consumption rate of the kiln
Air flow meter	Air flow rate which will be used to ensure required air to gas ratio
On-line temperature indicator	Monitor and control temperature of kiln in different zones
Non-contact temperature indicator	Surface temperature of kiln structure to assess insulation status

2.2 Energy efficient and renewable energy technology options

The efficiency of a kiln will depend on how efficient the combustion system is and secondly how best the generated heat is utilized. About 5 - 15% energy saving is possible from kilns used in ceramic industries. Some of the potential energy efficiency options are given below.

- Use of low thermal mass kiln car and furniture
- Conversion of kiln from oil to gas fired system
- Complete combustion with minimum excess air
- Operating the kiln at desired temperature.
- Reducing heat losses from the openings
- Minimizing wall losses by improving kiln insulation.
- Recovery and reuse of waste heat from fuel gasses
- Control of Chimney draught and kiln pressure
- Adoption of automation in kiln operation
- Use of variable frequency drives
- Replacement of flat belt with cogged V-belt in drive system
- Rooftop solar system

Adoption of energy saving measures would largely depend on base case scenario and other operating parameters. Some of the important options are summarised below.

2.2.1 Use of low thermal mass cars

Heavy refractory cars and saggars are generally used for carrying ceramic products inside the kiln. The dead weight of the refractories used in the cars is quite high in the ratio of 3 : 1. However, it may be noted that these refractories are only



support structure for holding the products inside the kiln and they do not take part in reactions taking place in formation of ceramic products. They are subjected to alternate heating and cooling cycles in each batch, which leads to substantial loss in heat input. This supporting deadweight used in the cars can be reduced to a large extent using hollow silicon carbide (SiC) pipes and thin cordierite plates with minimum width to provide required support. With this arrangement, the deadweight to product ratio can be brought down to about 1:1 or less. The reduction in deadweight further helps in improving the productivity by 100% or more.

2.2.2 Fuel switch over and insulation improvements in kilns

Fuel switch over to NG firing offers significant scope for improving energy efficiency. This would require inclusion of gas train and modification in air train. The oil burners have to be replaced with gas burners or dual fuel burners that would help in improving the combustion efficiency. Improved firing practices and use of better insulation material would help in improving the thermal efficiency of kilns. The overall energy saving potential of kilns is about 5%.

2.2.3 Application of energy efficient motors & VFDs

Generally, most of the existing motors in ceramic industries are old and inefficient. The energy saving measures in a ceramic unit include use of energy efficient motors in polishing area, replacement of smaller motors with a single large motor, adoption of energy efficient motors and VFD (variable frequency drives) in agitating tanks, material conveyor, kiln blower. These measures would help in achieving energy saving between 5-8%.

2.2.4 Adoption of rooftop solar system

Use of roof top solar system is a potential option for the ceramic industry considering the availability of large roof area and solar insolation. The actual generation potential will vary from one unit to another which would require detailed assessment. While installing the roof top solar system, the industry has to take into account the particulate matters in ambient air.

2.3 Best operating practices in a pottery unit

Adoption of advance and energy efficient technologies would definitely help in energy efficiency improvements of the pottery units. However, in order to realize the maximum benefits of the improved technologies, it is essential to operate the kiln optimally. This would require routine monitoring and maintaining various kiln parameters close to optimum levels. Optimum operating parameters can be achieved and maintained by adopting “Best Operating Practices” (BOP) in day to day kiln operation. Functionality, performance and deterioration of an equipment as well as facility as a whole would also depend on quality of “preventive” and “predictive” maintenance. Routine such maintenances include visual inspection, schedule servicing and functional testing to ensure optimum performance during entire life cycle of the equipment. With a combination of efficient technologies, schedule maintenance and better operating practices, pottery

industries could reduce energy consumptions as compared to other similar units operating in the cluster without such measures.

2.3.1 Kiln

Kilns are important segment in ceramic industries accounting for about 75% of energy consumption. The operating parameters of kiln like temperatures at different zones, excess air level, surface temperature etc. can influence energy consumption. Routine maintenance and keeping the key operating parameters within specified limits would help in reducing specific energy consumption. Some of the common practices may be adopted in order to ensure smooth operation of the kilns.

2.3.1.1 Maintaining correct air–fuel ratio

Correct air–fuel ratios must be maintained in order to ensure optimum combustion of fuel with minimum heat losses. An air–fuel ratio of 11 to 12 (volume by volume) is recommended for the kiln using natural gas. When the natural gas flow is increased or decreased, the air quantity is also increased or decreased proportionately to maintain the required air–fuel ratio. During the operation, the gas flow needs to be varied to maintain the kiln temperature depending upon the product being fired. Air flow is to be set in such a manner to avoid high excess air but at same time ensure proper and complete combustion. Higher excess air could be detected by (i) presence of oxygen, (ii) flame colour and (iii) low flue temperature.

In absence of airflow meter and pressure gauge, a unit-specific chart could be prepared by installing a U-tube manometer in air pipeline for calibration of air to fuel ratio. The chart comprises air pressure corresponding to gas flow to ensure complete combustion. Based on the chart, the air flow can be adjusted for variations in gas flow.

2.3.1.2 Flame colour

For the kiln operator, the colour of the flame is an important indicator of the status of combustion. A flame, like a snake's tongue indicates proper combustion occurring inside a furnace. If the air–fuel mixture is rich, the flame will be yellow and non-transparent. Smoke may be observed from the flame under such conditions. If the air–fuel mixture is lean, the flame will be red. If the air–fuel ratio is correct, the flame will be white or pale blue and transparent, indicating proper combustion. Correct air–fuel ratios must be maintained based on type of fuel in order to ensure optimum combustion while minimising formation of unburnts. When the firing rate of fuel is increased or decreased, the air quantity is also proportionately increased or decreased to maintain the required air–fuel ratio. The table provides the temperature for different flame colours.

Flame colour vs. kiln temperature

Colour of flame	Temperature (°C)
Initial red	500-550
Dark red	650-750
Cherry red	790-800

Bright red	850-950
Yellow	1050-1150
Initial white	1300
Full white	1500

2.3.1.3 Optimum capacity utilization

The capacity utilization (commonly known as “loading”) of a kiln is one of the key factors affecting the efficiency. The loading of a kiln includes preparation of material to feed, amount of material placed, arrangement inside the kiln and the residence time inside the kiln.

2.3.1.4 BOP for gas based kiln

A typical gas based tunnel kiln used in pottery industries can achieve the following benefits using better operating practices.

Best practices in gas based tunnel kiln

Area	Target	Approach	Benefits
Kiln top and side walls	Reduction of average surface temperature	Routine measurement of surface temperature	Potential scope to reduce NG consumption
		Improve insulation	Low workplace temperature
Kiln internal temperature	Maintain optimum temperature	Monitor kiln temperature at regular interval	Achievement of optimum gas consumption
		Gradually control gas and air flows	
Excess air flow	Maintain optimum air-fuel ratio for complete combustion	Routine monitoring of oxygen level in flue gas	Reduction in flue gas losses
Kiln furniture	Kiln cars	Low thermal mass cars	Increased productivity

2.3.2 Raw material processing

The improvement in existing milling practices can be achieved through the following.

- i. Always operate the ball mill at its critical loading point. The material loading of the ball mill is a critical parameter in determining the energy consumption. Specific energy consumption (SEC) will increase if the ball mill is loaded below/above the critical loading point.
- ii. Use grinding media (pebbles) in three different sizes for better and efficient grinding of raw material.
- iii. Preferable to use high alumina balls and internal lining for consistent quality with higher efficiency

- iv. Check the mesh size of the slurry - when it reaches the required value, switch off ball mill/blunger.
- v. Regularly monitor batch time.

2.4 Fault diagnosis and trouble shooting

Kiln system in a pottery industry consumes maximum energy and this is the heart of the process steps in manufacturing pottery products. This section provides some of the common fault diagnosis and troubleshooting approaches in kiln system (kiln, gas train and air train) for easy reference of kiln operators.

2.4.1 Kiln operation

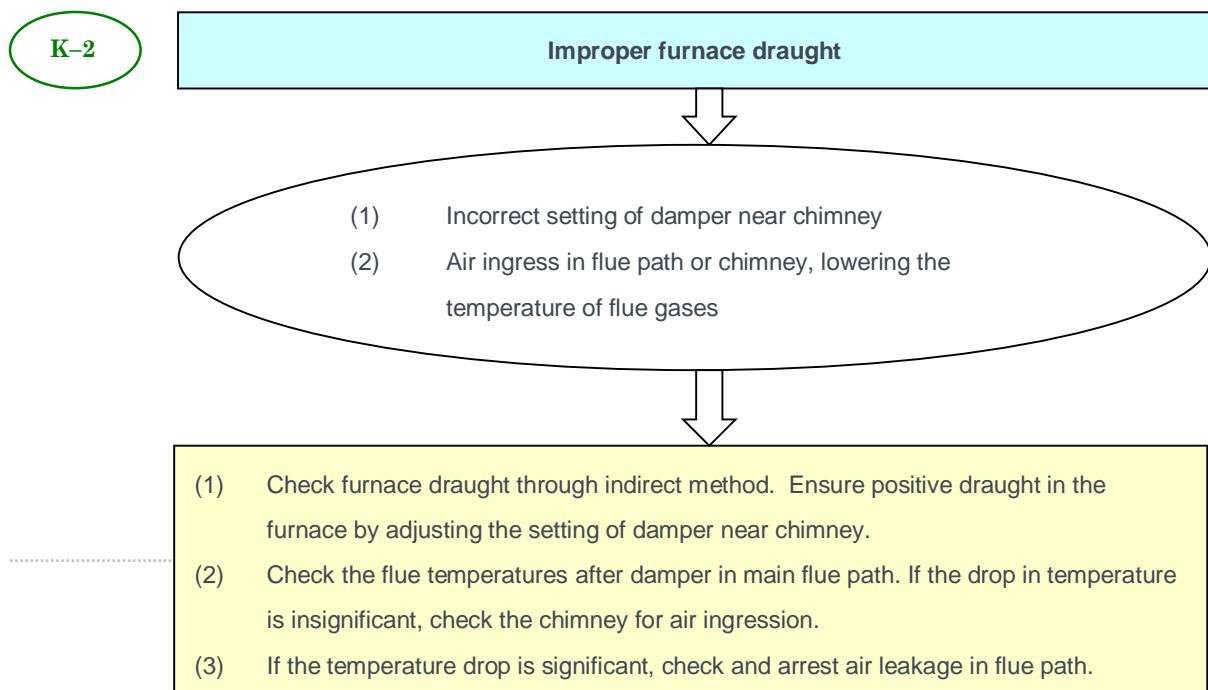
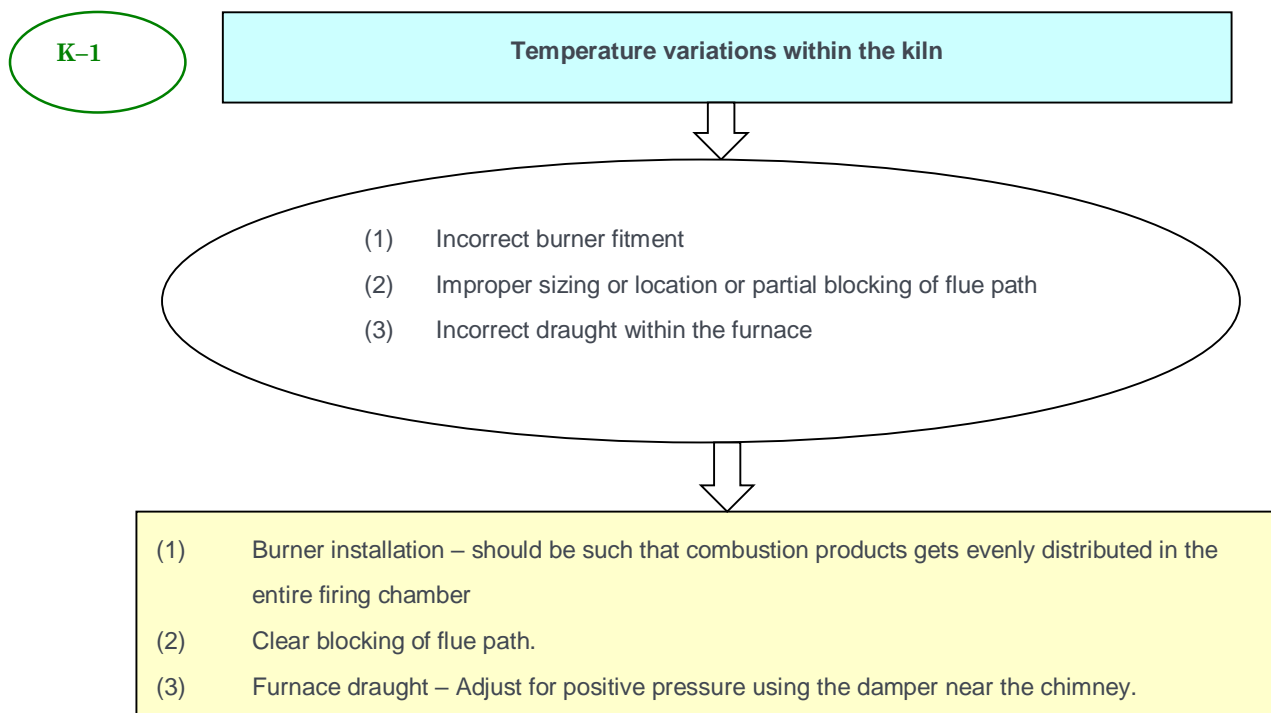

K-3

Incorrect kiln temperature

- (1) Faulty temperature indicator
- (2) Improper furnace draught
- (3) Incorrect air and gas flow

- (1) Cross check temperature indicator. Use different indicator/ compensating cable. Repair/ replace the faulty meter.
- (2) Ensure slightly positive furnace draught. You will observe furnace temperature start rising immediately.
- (3) Slowly increase gas and air flows. Maintaining pre-set air to gas ratio. Re-adjust the furnace draught.

K-4

Delay in firing schedule

- (1) Extra-long flame emerging from car entry
- (2) Improper filling of kiln car
- (3) Incorrect furnace temperature/ draught
- (4) Change of chemicals in batch requiring higher temperatures

- (1) Check with Problems 2 & 3 to adjust furnace temperature
- (2) Adjust damper and ensure slightly positive draught as per Problem K-2.
- (3) Check and follow routine car loading practices

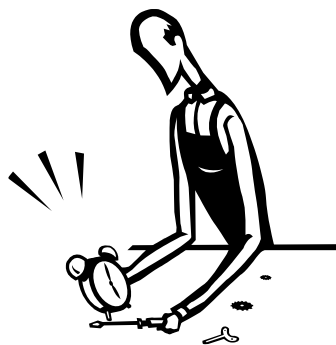

K-5

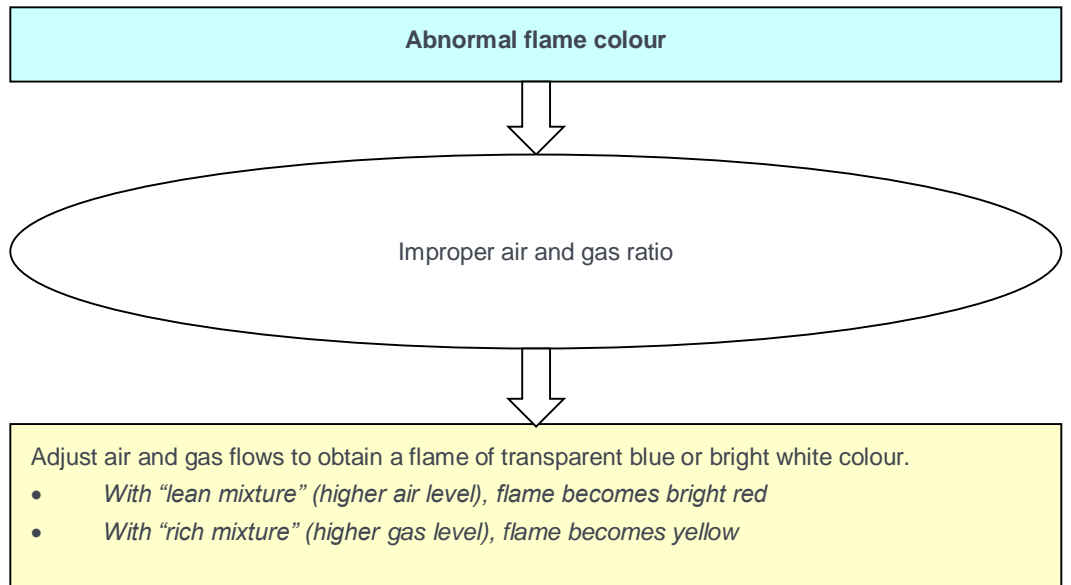

2.4.2 Gas train

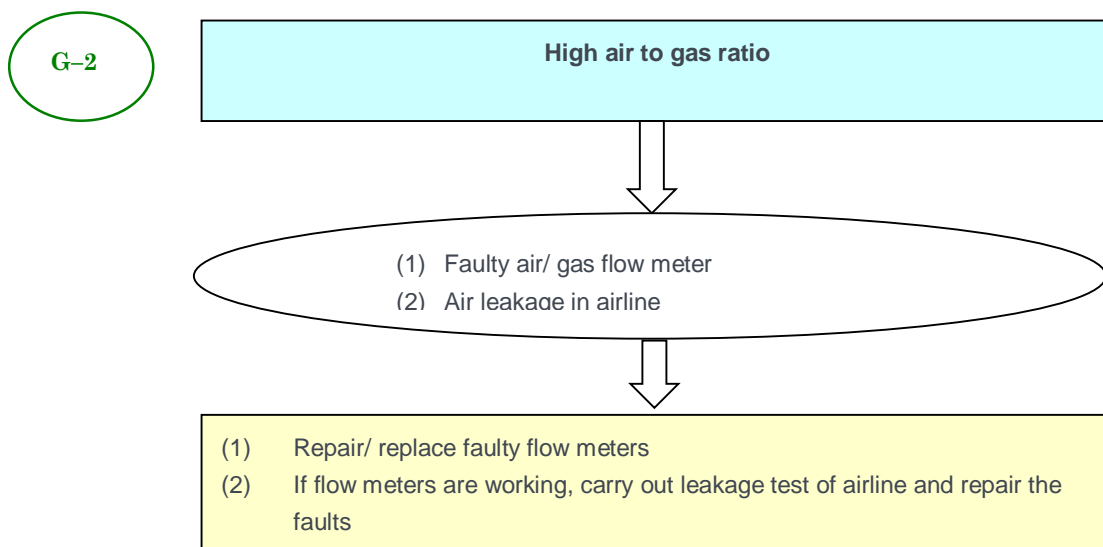
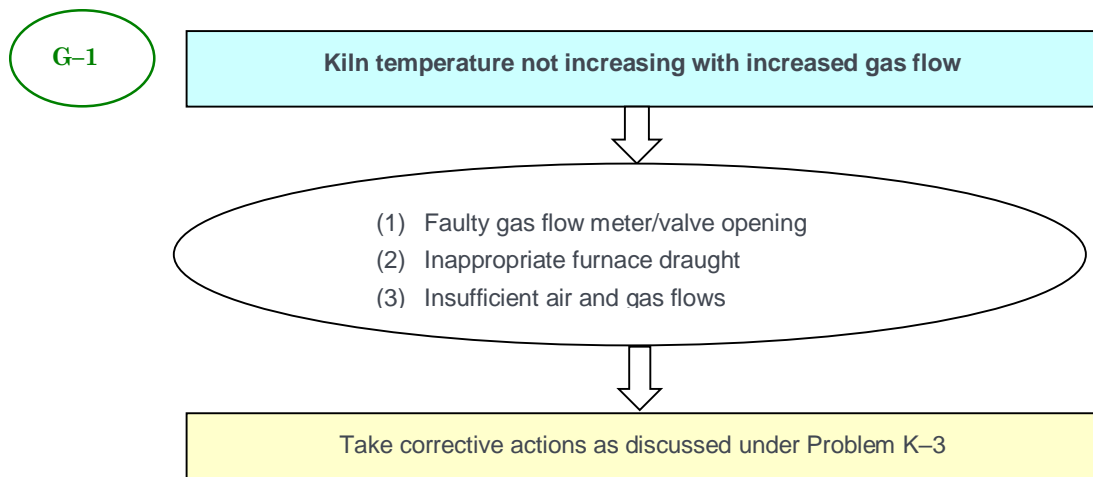

G-3

Incorrect reading of gas flow meter

- (1) Gas flow meter not installed as per supplier's instructions.
- (2) Absence of earthing wire in electrical power connection
- (3) Flow meter is due for calibration/ maintenance
- (4) Flow meter is not properly calibrated maintenance

- (1) Ensure proper installation of gas flow meter according to the supplier's instructions
- (2) Check power connection including earthing
- (3) Consult the supplier for guidance/ repair



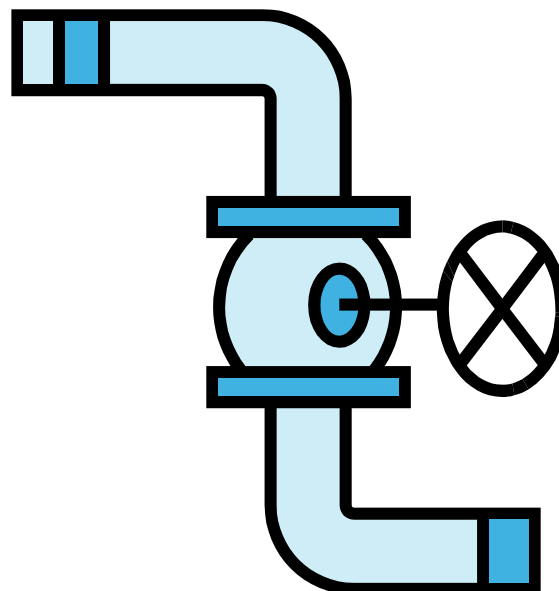
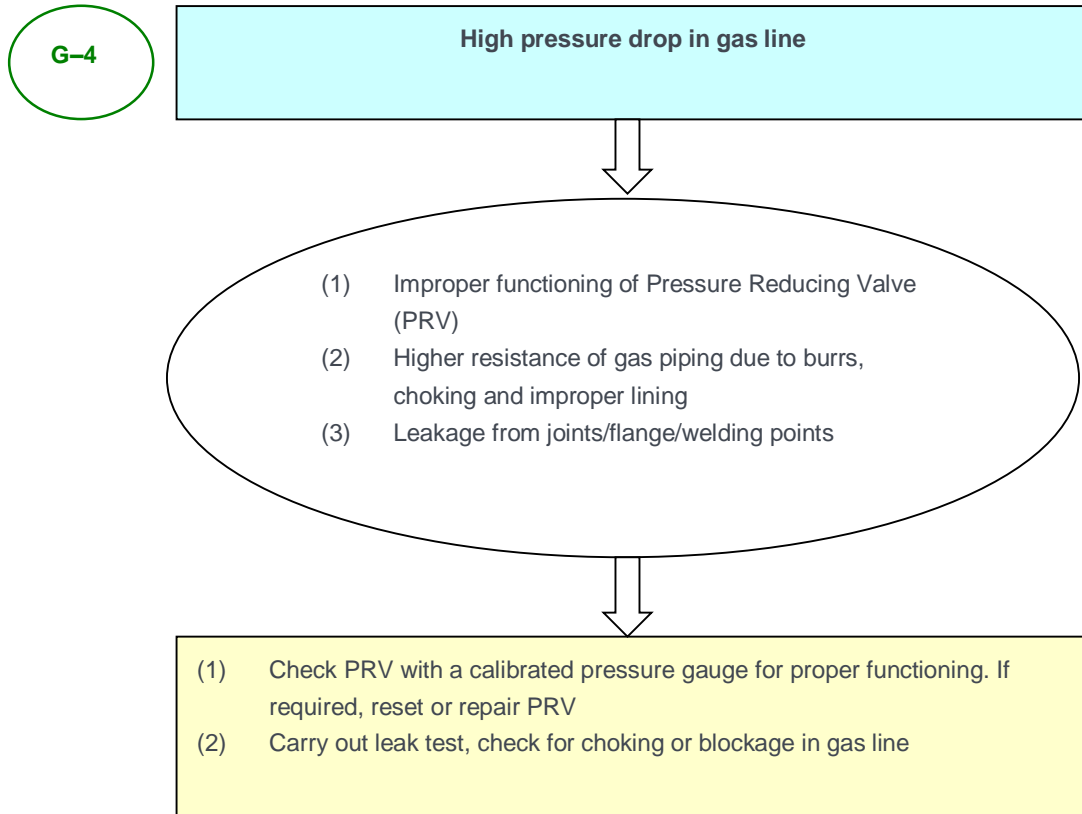

2.4.3 Air train

A-1

No air flow in spite of motor operating

- (1) Faulty power connection
- (2) Faulty impeller/ coupling

- (1) Check power connection
- (2) Check the direction of rotation of impeller and change by correcting the polarity of connection
- (3) Contact supplier in case impeller does not rotate or incorrect rotation



A-2

High vibration of motor

- (1) Improper balancing of impeller
- (2) Loose foundation and fittings

- (1) Contact supplier for rectification or replacement
- (2) Repair foundation and fittings



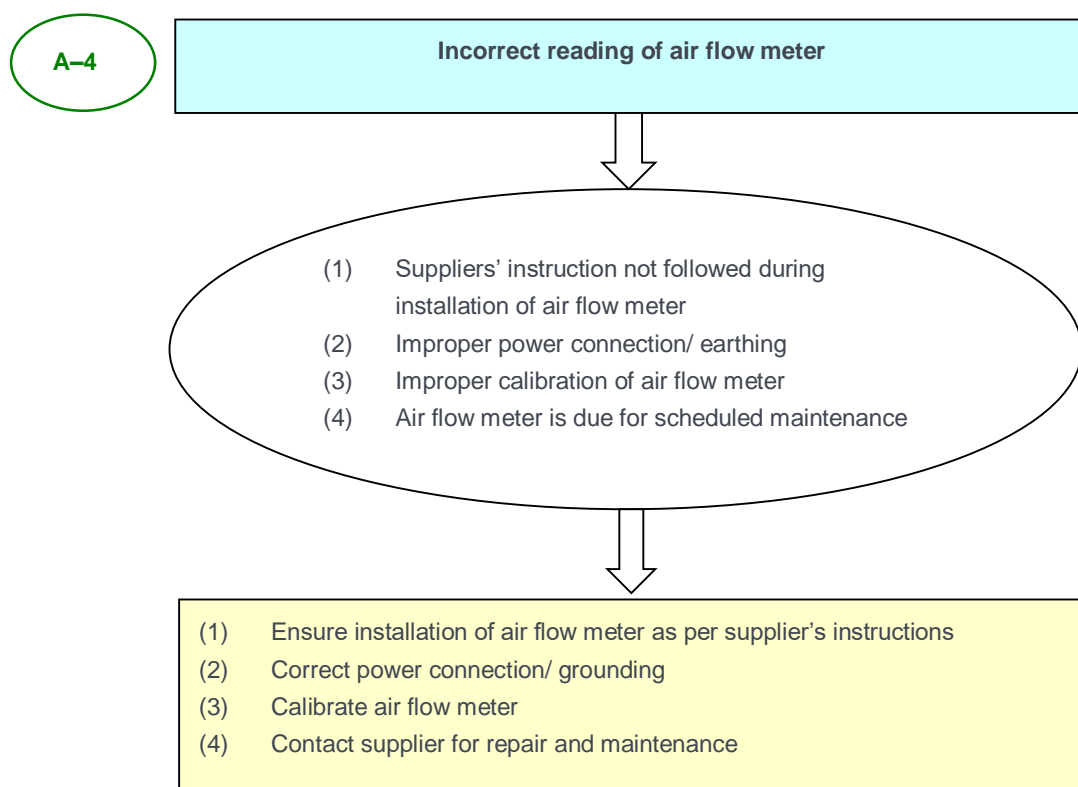
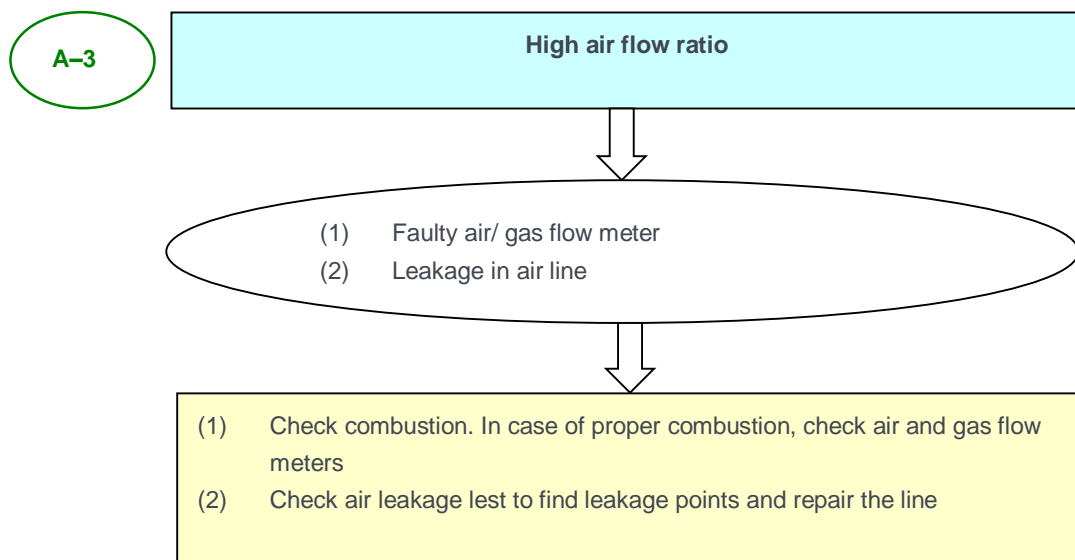

List of references

- (1) Energy efficiency in thermal utilities, Bureau of Energy Efficiency (BEE), Government of India
- (2) Reports prepared by TERI under TERI-SDC partnership project
- (3) Discussions with stakeholders in Khurja ceramic cluster

3.0 Module 2 – Advanced technologies for pottery industries

3.1 Background

There are more than 200 ceramic units operating in Khurja ceramic cluster which mostly cater to domestic market. The cluster is known for the manufacture of stoneware and bone china crockery products. The products include table wares, decorative wares, and porcelain insulators, both HT (high tension) and LT (low tension) types. Other products manufactured in the cluster are hospital ware, chemical porcelain, electro ceramics, kiln furniture, special ceramics, toys and non-china crockery products. A majority of pottery units in the cluster use tunnel kilns which is of continuous type. A few units use shuttle kilns which are of batch type engaged in the production of specialised products. Both types of kilns mainly use light diesel oil (LDO) and rubber processed oil (RPO), while a number of units have started using piped NG provided by Adani Gas, who is the local gas distributor in the cluster.

3.2 Advanced technological options for pottery industries

Although, there was a major shift in the cluster from switching over to inefficient coal fired downdraft (DD) kiln to tunnel kilns, several studies in the past clearly indicated that there are several energy efficient (EE) technology options available for the industry that would help in improving the energy performance as well as product quality. Further, there are a number of technology options available in raw material preparation and mould making areas. Some of the important EE options are discussed below.

3.2.1 Low thermal mass kiln furniture and car

Kiln cars are used in tunnel kilns to carry ceramic products for firing. Kiln furniture includes all those products used to support, hold or position ceramic wares/articles in kilns during firing process. Depending on loading pattern and the geometry of the wares, kiln furniture is designed. Hence, kiln furniture plays a vital role in energy saving. The following properties are important while selecting kiln furniture (1) retaining strength at a higher operating temperature, (2) resistance to thermal shock, (3) resistance to abrasion, (4) excellent emissivity and (5) good thermal conductivity.

Different types of kiln furniture used in the kiln include batt, post, support, beam, bar, half collar, ring, tray, sagger, setter and crank. In a tunnel kiln, about 19 cars are present at any point of time during normal operation. It comprises 7 cars in preheating zone, 3 cars in firing zone and 10 cars in cooling zone. Thus the kiln cars along with kiln furniture and ceramic products are subjected to preheating, firing and cooling on a continuous basis.

With a large deadweight ratio of car to product of 3:1, this results in substantial heat losses and higher Specific Energy Consumption (SEC) of the kiln. The heavy refractory material used in kiln car can be replaced with silicon carbide beam and less thickness of support plates of varying width as per size and shape of products. Typically, the kiln furniture to product ratio reduces from 3:1 to 1:1. With use of low thermal mass material, the firing and cooling processes leads to substantial increase in push-rate of kiln cars leading to high production rates. However, the kiln needs to adhere to certain cooling rate of products after firing, which otherwise may lead to cracks in products and hence affect kiln yield. Hence it is required to increase the length of all the zones. In a typical tunnel kiln in Khurja, the modification in kiln furniture would entail an increase of kiln length from 120 feet (36 metre) to 180 feet (54 metre).



Traditional kiln furniture

Some of the advantages of tunnel kiln using low thermal mass kiln cars include the following:

- Lower weight of kiln car as deadweight ratio of kiln car to product falls from the ratio 3:1 to 1:1
 - Increased production
 - Reduction in energy consumption

Low thermal mass kiln furniture and car

Kiln cars are used in tunnel kilns to carry ceramic products for firing. Kiln furniture includes all those products used to support, hold or position ceramic wares/articles in kilns during firing process. Depending on loading pattern and the geometry of the wares, kiln furniture is designed. Hence, kiln furniture plays a vital role in energy saving. The following properties are important while selecting kiln furniture (1) retaining strength at a higher operating temperature, (2) resistance to thermal shock, (3) resistance to abrasion, (4) excellent emissivity and (5) good thermal conductivity.

Different types of kiln furniture used in the kiln include batt, post, support, beam, bar, half collar, ring, tray, sagger, setter and crank. In a tunnel kiln, about 19 cars are present at any point of time during normal operation. It comprises 7 cars in preheating zone, 3 cars in firing zone and 10 cars in cooling zone. Thus the kiln cars along with kiln furniture and ceramic products are subjected to preheating, firing and cooling on a continuous basis.



Low thermal mass (silicon carbide) kiln furniture

With a large deadweight ratio of car to product of 3:1, this results in substantial heat losses and higher Specific Energy Consumption (SEC) of the kiln. The heavy refractory material used in kiln car can be replaced with silicon carbide beam and less thickness of support plates of varying width as per size and shape of products. Typically, the kiln furniture to product ratio reduces from 3:1 to 1:1. With use of low thermal mass material, the firing and cooling processes leads to substantial increase in push-rate of kiln cars leading to high production rates. However, the kiln needs to adhere to certain cooling rate of products after firing, which otherwise may lead to cracks in products and hence affect kiln yield. Hence it is required to increase the length of all the zones. In a typical tunnel kiln in Khurja, the modification in kiln furniture would entail an increase of kiln length from 120 feet (36 metre) to 180 feet (54 metre).

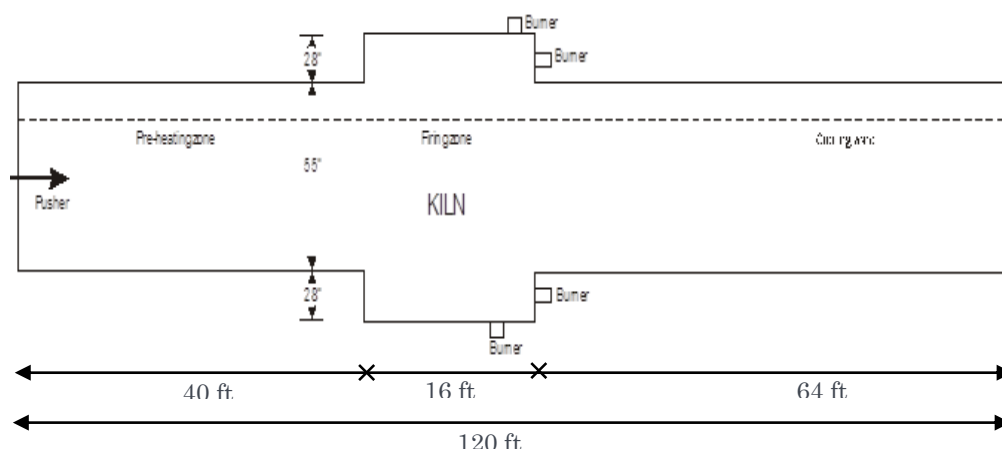

Tunnel kiln length with conventional kiln car

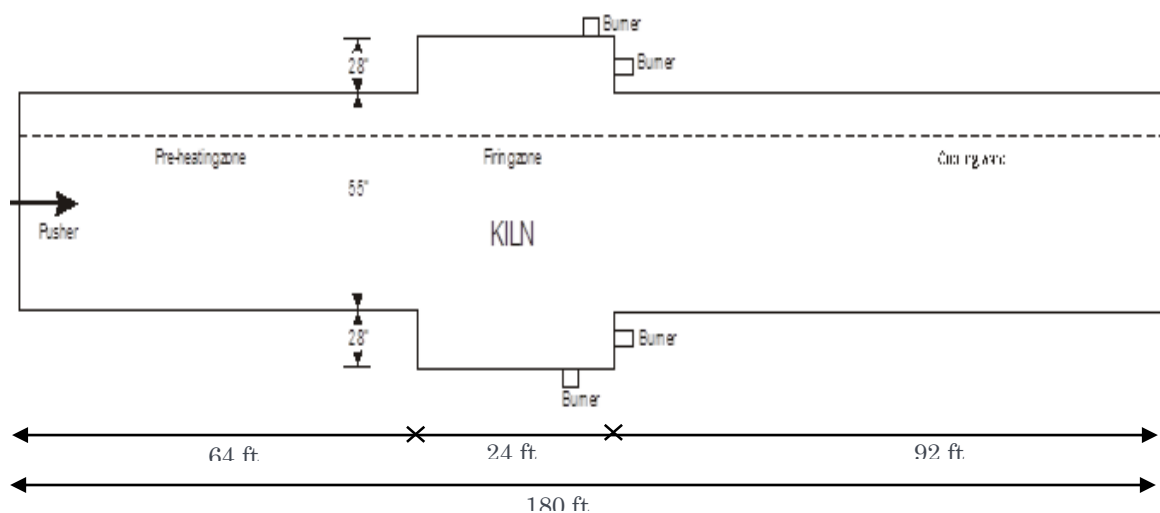

Tunnel kiln length with low thermal mass kiln car

Some of the advantages of tunnel kiln using low thermal mass kiln cars include the following:

- Lower weight of kiln car as deadweight ratio of kiln car to product falls from 3:1 to 1:1

- Increased production

Conventional kiln car vs low thermal mass kiln car

Parameter	Conventional kiln car	Low thermal mass kiln car
Kiln length (feet)	120	180
Kiln car : Product weight ratio	3:1	1:1
Push rate of car (minute)	50-60	20
Production (no. of pieces/day)	50,000	70,000
LDO consumption (lit/day)	500	500
Energy saving		20%
Investment (Rs lakh)	20	25

- Reduction in energy consumption

3.2.2 Pyro block insulation for kiln roof

The tunnel kilns in Khurja cluster extensively use folded ceramic fibre modules as insulation for side walls and roof structure. These modules are generally prepared at site using ceramic blanket roll. It is essential to provide sufficient insulation both at firing zone and either sides of firing zone joining with preheating and cooling zones. The select insulations are to be high temperature compatible as the temperature of firing zone is about 1150-1200°C. The roof temperatures are always higher than sidewalls, as combustion products generally tend to travel upwards. Use of manually folded ceramic blanket has inherent imperfection compared to machine folded branded product offered by reputed ceramic industries. Machine folded ceramic block behaves like a monolithic structure and provides better insulation. Due to more joints involved in folded type, the performance of insulation is moderate.



Folded ceramic fibre blanket



Pyrobloc module

A few advantages of the monolithic or mono-block ceramic products such as pyrobloc modules include the following:

- High compressed density of more than 240 kg/m³ which leads to better insulation i.e. low thermal conductivity (K-value)
- Easy to compress from all sides (both vertical and horizontal) and therefore shrinkage of fiber at high temperature can be arrested
- Easy to cut to any shape at site or procured custom designed for specific application
- Fast and easy installation

3.2.3 Kiln automation and safety systems

The tunnel kilns are operated manually in almost all pottery units in the cluster. In order to have close control of product quality, optimum yield and key operating parameters, it would be beneficial to include automation of kiln operation. Some of the important kiln automation options are given below.

Temperature control

There is limited instrumentation to monitor furnace temperatures in different zones - preheating, firing and cooling. The number of monitoring points of furnace temperature can be enhanced and a PLC based control system can be added to control temperatures across different zones. Any deviation observed can be auto corrected and corresponding interlinking can be actuated for overall control

Air to fuel ratio controller

The fuel firing is varied manually by the operators based on eye judgment and skills. However, the corresponding change in air flow is generally not done, which results in improper air to fuel ratio and higher heat losses in flue gases. An oxygen analyser can be installed to measure excess air ratio, which can be used to control motorized valves to account for variations in operating parameters. For example, if low temperature is observed in firing zone, the NG flow can be increased with PID controller to restore set operating temperature and also maintain proper air to fuel ratio by increasing air flow with respect to increased NG flow through electrical signal from PID to motorized valve correspondingly.

Cooling zone temperature trimmer

The air flow in cooling zone is generally adjusted based on the product quality as observed when they come out of tunnel kiln. With this, significant production and time loss can occur. The temperature deviations observed in cooling zone temperature can be adjusted automatically by actuating a motorized valve to increase/ decrease and trim air flow in different sections of cooling zone instead of existing manual practices.

Other safety systems

The gas train safety devices include low/high pressure safety shut-off valve (SSOV), pneumatically operated safety guard against malfunctioning of Pressure Reduction Valve (PRV) system. The PRV is a spring loaded diaphragm based mechanical device and maintains two set pressure (maximum and minimum) respective of input supply pressure of

natural gas. The SSOV system locks off NG supply in case of PRV fail to maintain set pressures. In case of NG pressure either less or more than the recommended safe limit of burner. It can lead to bursting due to accumulation of NG within the kiln chamber.

The SSOV also locks off NG supply in case of electrical power failure as blower will discontinue to supply combustion air to burner still power supply is resumed. However, NG will keep accumulating inside the chamber if power supply delayed for extended period. The SSOV operates on the following conditions and locks off NG supply as well as raise an alarm to undertake appropriate corrective measures.

- ✓ PRV fails to maintain maximum set pressure
- ✓ PRV fails to maintain minimum set pressure
- ✓ Electrical power break down

Apart from SSOV, generally a non-return valve (NRV), a mechanical device is provided in gas line near to burner, which allows unidirectional flow of gas and prevents return travel of flame during sudden discontinuation of combustion air flow. This NRV acts as fire safety device during such occasion. The burner system needs to be equipped with flame monitoring and control system so that NG supply is switched off in case of flame out or no flame conditions. Further, PID system will also be integrated to switch off blower to stop combustion air flow to burner.

Similarly, airline could be equipped with pressure transducer to act in tandem when conditions of activation satisfied for switching off NG supply i.e. for low air pressure or no air supply to burner. The industry has to ensure interlink and integrate all safety devices as provided in both gas train and air train to ensure complete safety of the kiln system.

3.2.4 Roller hearth furnace

Tunnel furnaces are extensively used in the cluster for firing of ceramic products. At present the total firing cycle in a tunnel kiln is about 18-20 hours with 45 to 50 minutes push time. The industry is in the process of adopting low thermal mass kiln car & furniture to reduce heat load and increase production rate. One of the technology options available for pottery units is adoption of Roller Hearth (RH) furnace in place of tunnel kilns. RH furnaces do not use kiln cars and hence there is no initial investments towards kiln cars as well as for their maintenance during kiln operation. With elimination of deadweight completely, the total firing cycle in roller hearth furnace is about 6 hours, which is substantially lower. This type kiln is also suitable for gas fired system.



Roller hearth furnace

3.2.5 High alumina ball mill and alumina coating

A ball mill is a type of grinder used to grind and blend raw materials. It works on the principle of impact and attrition i.e. reduction in size of raw materials is achieved through impact as the balls drop from near the top of the shell. A ball mill consists of a hollow cylindrical shell. The axis of rotation of the shell may be either horizontal or at a small angle. The length of the mill is approximately equal to its diameter. The grinding media is river pebbles or mined pebbles of different sizes in a conventional ball mill. The inner surface of the cylindrical shell is strengthened with 5 inch thickness refractory lining using brick, silica sand white cement as mortar.



View of ball mill



Pebbles in conventional ball mill

The raw material clay is fed in ball mill to reduce the size and aid proper mixing. In Khurja, large size raw materials which were being used in the units have now been replaced by powdered materials. In a conventional mill, equal quantity of raw material, pebbles and water are added. The speed of motor in a ball is generally maintained low at about 8-9 rpm (rotations per minute). During regular operation, ball mills are operated for about 18 hours per day. In conventional system, the pebbles lose their shape and lining of inner surface deteriorated very frequently. Owing to this, the efficiency of ball mills reduces drastically, which increase the overall

Benefits of high alumina ball mill and refractory lining

The existing pebble-refractory lining based ball mill can be replaced with a high alumina ball and refractory lining based ball mills, which would result in significant monetary savings.

Basis:

Ball mill processing a raw material of 3 tonne per batch connected with a 15 hp (11.2 kW) motor, considering 18 hour operation per day for 300 days.

Electricity consumption with conventional system = 48,384 kWh/yr

Electricity consumption with high alumina system = 38,707 kWh/yr

Energy saving = 9,677 kWh/yr

Energy cost saving = Rs 64,835 per year

Monetary saving with better grinding medium = Rs 58,500 per year

Monetary saving with improved lining = Rs 5,583 per year

Total monetary saving = Rs 1,28,918 per year

Incremental investment for high alumina ball mill = Rs 2,58,000

Simple payback period = 2 years

grinding time leading to increase in electricity consumption per tonne of raw material. In typical cases, almost 75% of pebbles are replaced every 6 months. Further, the change in weight ratio between the raw material and pebbles cause dynamic imbalance, which affects the performance of the system.

The existing ball mill can be retrofitted with an energy efficient system. It uses high alumina refractory lining, the life of which is higher than conventional refractory lining due to less wear and tear. The mined/ river pebbles will be replaced with high alumina balls, which would require a replacement rate of only 20% of total grinding medium. The advantages of using high alumina based ball mills include the following:

- Higher grinding efficiency reduces overall downtime and increases the availability of the system.
- Reduces energy consumption per unit of raw material prepared
- Enhances dynamic balancing and reduce pebble replacement cost
- Reduces labour cost both in batch preparation and re-lining due to low rate of wear and tear



High alumina balls

3.2.6 Automatic roller jigger machine

Jigger machines are used to provide shape to circular products. Jigger machines are generally operated for about 8 hours per day. Manual jigger machines are extensively used in the cluster. With manual operation, the production rate is limited, which depends on skills of the operators. Moreover, the yield from fired products also goes down with manual process. To address the issues related to production rate and yield, one of the options available to the industry is automatic roller jigger head machines. Automation increases the electrical load of the system - from 1 motor (each 1 hp) to 3 motors (each 1 hp). The overall production of good quality product increases by about 20-25%.



Automatic roller jigger machine

Conventional jigger machine vs automatic roller jigger machine

Parameter	Conventional jigger machine	Automatic roller jigger machine
Connected load	1 hp	3 hp
Production rat	3000 piece/8 hr	3500 piece/8 hr
Yield	95%	100%

3.2.7 Energy efficient motors

A significant number of motors used in ceramic industries for various process applications are old and inefficient due to wear and tear. These areas include ball mills, pumps, kiln blower, etc. which consume more electricity due to use of inefficient motors. These old and inefficient motors can be replaced with energy efficient (EE) IE3 motors which would result in significant energy saving. The replacements of inefficient motors are more beneficial for areas such as ball mills which are used extensively for about 20 hours per day using 15 HP motor. An energy saving potential of 5-6% exists with replacement of standard motors with IE3 motors.



Energy efficient motors

Savings with energy efficient motors in ball mill

Parameter	Unit	Standard	IE3 motor
Rated capacity	(kW)	15	15
Efficiency of motor	(%)	90.6%	92.1%
Loading of motor	(%)	70.0%	70.0%
Operating duration	(hr)	6000	6000
Energy consumption	(kWh/yr)	69,536	68,404
Energy saving	(kWh/yr)	1,133 (1.6%)	
Price of electricity	(Rs/kWh)	8.00	8.00
Energy cost saving	(Rs/yr)		9060
Investment for EE motor	(Rs)		20570
Payback period	(year)		2.3

Energy efficiencies of Standard (IE2) IE3 motors

kW	2-Pole			4-Pole			6-Pole		
	Frame size	Efficiency%		Frame size	Efficiency %		Frame size	Efficiency %	
		IE2	IE3		IE2	IE3		IE3	IE3
0.37	71	72.2	75.5	71	70.1	73	80	69	71.9
0.55	71	74.8	78.1	80	75.1	78	80	72.9	75.9
0.75	80	77.4	80.7	80	79.6	82.5	90S	75.9	78.9
1.1	80	79.6	82.7	90S	81.4	84.1	90L	78.1	81
1.5	90S	81.3	84.2	90L	82.8	85.3	100L	79.8	82.5
2.2	90L	83.2	85.9	100L	84.3	86.7	112M	81.8	84.3
3.7	100L	85.5	88.8	112M	86.3	88.4	132S	84.3	86.5
5.5	132S	87	89.2	132S	87.7	89.6	132M	86	88
7.5	132S	88.1	90.1	132M	88.7	90.4	160M	87.2	89.1
11	160M	89.4	91.2	160M	89.8	91.4	160L	88.7	90.3
15	160M	90.3	91.9	160L	90.6	92.1	180L	89.7	91.2
18.5	160L	90.9	92.4	180M	91.2	92.6	200L	90.4	91.7
22	180M	91.3	92.7	180L	91.6	93	200L	90.9	92.2
30	200L	92	93.3	200L	92.3	93.6	225M	91.7	92.9

Source: IS 21615:2011 (3-phase, 50Hz, single speed & squirrel cage induction motors)

3.2.8 Energy efficient fans

Green-ware drying is an important process in a pottery unit before firing in the kiln. The pottery units use extensively ceiling fans for the purpose of drying. The conventional ceiling fans use about 70-80 watt of electricity at full speed. The conventional fans can be replaced with energy efficient (EE) ceiling fans of 28 watt capacity, which would help in saving energy to about 60% used by ceiling fans in pottery units.

The EE fans are equipped with brushless DC (BLDC) motors which use electronic device in place of mechanical commutator used in conventional motors. BLDC motor controls speed in a closed-loop system. Based on signal input detected by the sensor, the transistor in the drive circuit turns on and off thereby rotating the motor. The hall effect sensor, which is a transducer varies output voltage in response to changes in magnetic field. The sensor is used to detect the position of permanent magnet.



Energy efficient ceiling fan

The savings would be significant as ceiling fans are used for almost 20 hours per day throughout the year. Some of the advantages of EE fans include the following:

- Lighter in weight
- No slip due to synchronous type
- Smart remote control with sleep and timer mode
- No humming noise and heating
- Longer life as they can sustain hot and dusty environment
- Attractive payback period

Monetary benefits with energy efficient ceiling fans

Parameter	Conventional fan	Energy efficient fan
Power rating (watt)	80	28
Energy consumption (kWh/yr)	168	480
Energy saving (kWh/yr)		312
Energy costs (Rs/yr)	1344	3840
Monetary saving (Rs/yr)		2496
Investment (Rs)	1700	3500
Incremental investment (Rs)		1800
Payback period (month)		9

300 days @ 20 hours per day

3.2.9 Solar photovoltaic for power generation

The pottery units in the cluster use electricity for several applications such as raw material preparation and operating utilities such as pumps, compressors, motors and lighting. On an average, electricity accounts for about 20% of total energy share in a pottery unit. Electricity is sourced from grid and DG sets are used only in case of power failure. A part of the electricity requirements can be met by installing solar photovoltaic (SPV) panels on the roof structure of the units. Although, there are two types of solar plants are in use (on-grid and off-grid), on-grid is more suitable for industrial applications, which can be connected with grid through a 'net metering system. Some of the differences between on-grid and off-grid systems are provided below.



SPV for power generation

SPVs: On-grid system vs off-grid system

On-grid system	Off-grid system
No battery backup required	Requires batter backup
Low overall investments	Expensive
Net metering is available so that the excess electricity generated can be exported to grid	No net metering
Preferred system where grid is available	Suitable for non-access to grid
Low replacement costs as no recurring costs for battery replacement on a periodical basis	High maintenance costs

3.2.10 Quality assurance for fabrication

This section provides a ready reference for inspection and testing guidelines which need to be observed during the fabrication work for different utilities in the industry.

Inspection

The inspection activities during manufacturing are divided into the following: (1) Inspection of raw materials, (2) Inspection during fabrication, (3) Inspection of complete assembly at fabrication site and (4) Inspection of complete assembly at client (end user) site.

i) *Inspection of raw materials*

Inspection of raw materials should be carried out at the time of their purchase. The following conditions need to be ensured during procurement of raw materials.

Test certificates. Supplier(s) must provide the manufacturer test certificates of concerned items, indicating that the materials purchased are according to the required technical specifications.

Chemical and physical test. Samples from each lot of metallic are verified for their chemical composition and physical properties to ensure that the material belongs to the correct grades.

Visual inspection. All materials are to be checked visually for dents, cracks, corrosion, distortion, straightness, etc. Stainless steel (SS) material must be checked by magnetic test (a magnet should not attract SS material).

Dimensional inspection. (a) The length, width, thickness, outside diameter and inside diameter as applicable must be checked against the approved drawings after removing burrs, if any. (b) The lengths of bolts must be checked. Random checks must also be made to ensure proper movement of nuts over the bolts.

ii) Inspection during fabrication

- The dimensions of materials are to be checked using proper gauge against the approved drawings. Burrs if any after drilling must be removed.
- Welding of the pieces to be carried by Tungsten Inert Gas (TIG) welding after first establishing the procedure on mock-up test pieces. In order to check for welding defects in joints, the dye penetration test is to be carried out after welding.

iii) Inspection of complete assembly at fabrication site

A final dimensional check-up must be carried out after assembly of the entire system as per approved drawings/customer requirements, to ensure proper alignment and to avoid any mismatch after integration at the client site.

Individual sub-system of a utility is to be tested by hydraulic and pneumatic tests for leakage and pressure holding as per requirements.

The system is to be assembled together and aligned properly, following which the complete assembly too must be subjected to hydraulic and pneumatic tests.

iv) Inspection of complete assembly at end-user site

After receipt of the completed assembly at the client site, visual examination must be carried out to identify damages or distortion during transportation.

Hydraulic test to be carried out by applying pressure of 3 kg/cm² and one hour holding period, all weld joints to be checked for water leakage. No Drop of pressure is permissible. Similarly, pneumatic test to be carried out by applying air pressure of 2 kg/cm², all weld joints to be checked by application of soap solution. No drop of pressure is permissible.

The modules are to be assembled together and aligned properly. Thereafter, the complete recuperator assembly is subjected to hydraulic and pneumatic test as per Quality Assurance Plan while in stand-alone arrangement, that is, before taking it online.

List of references

- (1) Reports prepared by TERI under TERI-SDC partnership project
- (2) Discussions with stakeholders in Khurja ceramic cluster
- (3) Information collated from various equipment suppliers

4.0 Module 3 – Financing schemes and DPR preparation for EE projects

4.1 Introduction

Energy efficiency projects may be identified by either internal expert or hired external agency through day to day performance monitoring and analysis of observed data. The identified projects are to be screened for technical and financial viability before deciding to implement any project demanding higher capital investment. It is essential to justify capital investment in any energy efficiency project through financial appraisal. The standard financial analysis tools can reveal status of various indicators such as IRR (internal rate of return), NPV (net present value), projected cash flow and its sensitivity to various changing scenarios, average payback period, etc., which will indicate overall post tax return from investment as well as the viability of the project

All these tools are quite reliable, depending on the accuracy of evaluation of the cash inflow and outflow, estimation of the discount rate (cost of capital), and prediction of the possible rate of increase of the energy price. Within these limitations, the most precise method is the 'present value criterion', which compares the present value of all-future after-tax cash inflow and outflow over specified period of time to the present value of the cost of investment. The different financial tools for assessment of the investments are summarized below.

4.1.1 Average rate of return (ARR)

It is a basic tool for financial analysis based on the projected future annual cash savings from the project, which is considered to be same. It provides a preliminary guide to investment decisions and indicates whether further analysis is required using more accurate tools. The estimation of ARR is described with the following example.

Example: Plant invested Rs 950,000 to replace existing compressor with alternative system to improve energy performance. The estimated year wise saving in energy cost for a period of five years are Rs 65,000 in the first year, Rs 71,000 in the second year, Rs 69,000 in the third year, Rs 70,000 in the fourth year, and Rs 72,000 in the fifth year. The total cumulative energy savings in five years is Rs 347,000. Dividing this number by the 5 years, we get Rs 69,400 as an average annual energy savings. Now to obtain ARR, divide Rs 69,400 by the initial capital investment of Rs 950,000, which is equal to 7.3%.

$$ARR (\%) = \frac{\text{average annual cash saving} \times 100}{\text{capital employed}}$$

Guideline- Invest in a project with higher ARR

4.1.2 Return on investment (ROI)

ROI is a profitability measure based on the cost of capital invested and evaluates the performance of a business or efficiency of an investment. The ROI of an investment can be calculated using following relation.

$$ROI (\%) = \frac{(Gain\ from\ investment - Cost\ of\ investment) \times 100}{Capital\ employed}$$

The 'gain from investment' refers to energy savings accrued from implementing an EE technology. The financial gain is to be estimated based upon the discounted value of the energy savings over the life time of the project. Return on investment is a very popular measure because of its versatility and simplicity. The project is considered to be financially viable if ROI from an investment is positive.

Discounted value of energy savings

Discounted value is an analysis based on time value for money (considering money is relative - A Rupee is worth more today than it is worth in the future). So the energy savings over the years have to be discounted to obtain their present value.

Guideline: Invest in a project with higher ROI

4.1.3 Simple payback period (SPP)

SPP is the time period required to recover the initial capital investment amount through net annual energy savings or cash flow return (annual benefits- annual expenses). It is calculated as the investment cost divided by the net annual energy saving.

$$Simple\ payback\ period\ (SPP\ in\ years) = \frac{Cost\ of\ project}{Net\ annual\ monetary\ savings}$$

Unlike the ROI method, the payback criterion has some limitations as it does not take into consideration the discount rate, the change in energy prices, or the lifetime of the investment project. It has one advantage over ROI in respect of precise indication of the annual benefit, namely the cash flow instead of profits. However, both suffer from the difficulty in justifying the threshold value beyond which no project should be considered. In practice, investment projects with a payback period of three years or less are considered viable as they normally have a positive net present value. Thus the payback period is often used as a "filter", calculating NPV when the payback period is over three years and accepting the project when it is less. The advantages of SPP are as follows.

- It is a simple calculation and easy to use by semi-skilled shop floor personnel
- It favours projects with substantial cash flow in initial years but rejects projects that generates substantial cash flow in later years instead of earlier

The limitations of SPP tool are:

- It fails to account for the time value of money
- It ignores potential cash flow beyond the payback period
- It only indicates time period to recover capital investment but ignores profitability

Guideline: Invest in a project with small SPP

4.1.4 Net Present Value (NPV)

The net present value (NPV) is the present value of the entire cash flow considering both out flow and inflow (energy savings) from a project under analysis in entire project life cycle, including any residual or salvage value of the equipment on disposal/ completion life cycle. In simple terms, the difference between the present value of energy savings (inflows) and the present value of cash outflows is NPV.

It is calculated using a given discount rate, also known as the hurdle rate and is usually equal to the incremental cost of capital. NPV is very useful analysis that enables the plant management to take an informed decision about whether to accept or reject a particular project. Project could be accepted if its NPV is more than zero, which indicates the investment would add value to the firm. In case of zero NPV, project could still be accepted if it has some strategic value for the firm. However, the project with negative NPV would subtract value from the firm and hence, should be rejected. The future energy savings are converted to present value using following formulae.

$$PV = \frac{FV}{(1 + i)^n}$$

Where,

FV – future value of energy savings

i - interest or discount rate or hurdle value

n – number of years under analysis

The NPV is then calculated by subtracting the initial cost of investment from the total PV of future energy saving from entire life cycle:

NPV = total PV- Initial cost of investment

NPV indicates the return that the management can expect from the project at various discount rates. It can also be used to compare various EE projects with similar discount rates and risks, as well as compare them against a benchmark rate. The advantages of NPP are given below.

- It consider the time value of money
- It consider entire cash flow stream during project life cycle including salvage value

Guideline:

NPV > 0 : Should be accepted

NPV = 0 : Should be accepted if the project has some strategic value

NPV < 0 : Should not be accepted

4.1.5 Internal rate of return (IRR)

IRR also referred as 'economic rate of return' is the highest discounted rate, which makes the present value of the energy savings / inflows (including residual or salvage value of the equipment from its life cycle) equal to the initial capital cost of the investment or equipment. In other terms, internal rate of return is the discount rate that makes the net present value equal ZERO. It is also the rate, which makes benefits to cost ratio ONE. A project is considered viable, if its IRR is greater than the returns (interest rate) offered by the bank/financial institution on investments/deposits made with them.

The formula for IRR is

$$0 = \frac{P_0 + P_1}{(1 + IRR)} + \frac{P_2}{(1 + IRR)^2} + \frac{P_3}{(1 + IRR)^3} + \dots + \frac{P_n}{(1 + IRR)^n}$$

where P_0, P_1, \dots, P_n equals the cash flows in periods 1, 2, . . . n, respectively; and IRR equals the project's internal rate of return.

As such, IRR can be used to rank several prospective projects a firm is considering. Assuming all other factors are equal among the various EE projects, the EE project with the highest IRR would probably be considered the best and undertaken first.

Guideline: Invest in a project with high IRR

4.2 Major financial schemes for MSMEs in India

The Government of India and respective State governments have announced various policies and schemes from time to time to address emerging issues and develop the MSME sector.

Most of the programmes & schemes for the development of the MSME sector are being implemented by Ministry of MSME through its field level organizations – state level MSME Development Institutes (MSME-DI) and National Small Industries Corporation Limited (NSIC).

Some of the important initiatives by the Government of India for development of the MSME sector as well as promotion of new technologies and energy efficiency are mentioned below.

- National Manufacturing Competitiveness Programme (NMCP)
- Credit Linked Capital Subsidy Scheme (CLCSS)
- Credit Guarantee Trust for MSEs ISO 9000 and ISO 14001 Certification Reimbursement Scheme
- Financial Assistance for using Global Standard (GS1) in Barcoding
- Sustainable Finance Scheme

- Subsidies/schemes for undertaking energy audits by various state governments such as Maharashtra, Gujarat etc.

4.2.1 National Manufacturing Competitiveness Programme (NMCP)

The programme was launched by the Ministry of MSME (MoMSME) to support SMEs to improve their competitiveness both in national and international trade market. It offers a bundle of 10 sub schemes that are listed below:

1. Lean Manufacturing Competitiveness Scheme
2. Enabling manufacturing sector to be competitive through Quality Management/Standards/Quality Technology Tools (QMS/QTT)
3. Promotion of ICT (Information and Communication Technology) in MSME sector
4. Technology and Quality Upgradation Support to MSMEs (TEQUP)
5. Marketing Assistance and Technology Upgradation Scheme
6. Marketing Support/ Assistance to SMEs (Bar Code)
7. Design clinic scheme for design expertise to MSME sector
8. Setting up of Mini Tool Rooms
9. National campaign for building awareness on Intellectual Property Rights (IPR)
10. Support for Entrepreneurial and Managerial Development of SMEs through Incubators

The relevant scheme for supporting EE project is TEQUP Scheme, which is summarized below.

The MoMSME launched the scheme TEQUP scheme during May 2010. The scheme under NMCP is focused specifically on improving energy efficiency in the MSME sector. It provides support for technical assistance for energy audits, preparation of DPRs and also offers significant capital subsidy to MSME units willing to adopt energy efficient technologies through a cluster approach. In addition, support is also offered to MSMEs in acquiring international and national Product Quality Certification. The scheme also provides MSMEs an opportunity to trade carbon credits through Carbon Credit Aggregation (CCA) centers. The TEQUP scheme is currently in operation, and the government has proposed to continue the scheme during the 12th Plan with enhanced budgetary support.

4.2.2 CLCSS Scheme

The CLCSS. One of the oldest schemes of MoMSME, it aims at facilitating technology upgradation in the MSME sector. It provides for 15% capital subsidy (limited to maximum Rs.15 lakhs) to eligible micro and small units for adoption of proven technologies approved under the scheme. At present there are over 1500 technologies under 51 sub-sectors that are eligible for subsidy under the scheme. Till March 2014, 28,287 units had availed subsidy of INR 1620 crores under the scheme.

4.2.3 Credit Guarantee Scheme

The Credit Guarantee Fund Scheme for Micro and Small Enterprises (CGTMSE) was launched by MoMSME and SIDBI. It aims to make available collateral-free credit to the MSEs to enable them to easily adopt new technologies. Both the existing and the new enterprises are eligible to be covered under the scheme. Under the scheme, collateral free loans up to 1 crores can be provided to micro and small scale units. Additionally, in the event of a failure of the MSME unit which availed collateral free credit facilities to discharge its liabilities to the lender, the Guarantee Trust would guarantee the loss incurred by the lender up to 75 / 80/ 85 per cent of the credit facility.

4.2.4 Scheme for Common facilities Center (CFC) in industrial cluster

A group of at least 25 registered SME ceramic units (formed as Special Purpose Vehicle-SPV) within a cluster can avail financial support under this scheme to establish CFC relevant to the industrial process being followed in the cluster. e.g. CFC having tunnel kiln for firing green pottery products in the ceramic cluster. The brief details of the scheme are mentioned below.

Operating authority - The office of Development Commissioner, MoMSME

Eligibility criteria - SPV comprising at least 25 registered located in the cluster

Financial support - 70 % by Central Government and balance 30 % by SPV /State government for project value up to Rs 15 Crores.

The cluster members can apply through the State government or its autonomous body for DSR (Diagnostic Study Report) for which a grant of up to Rs 2.5 Lakhs is available. The report must be submitted within 3 months to DC MSME which will justify the creation of CFC. On acceptance of the DSR by DCMSME, a DPR is to be submitted for which a funding of Rs 5 Lakhs is available. The DPR, which needs to be appraised by SIDBI establishes the tech-economic viability of the project. On acceptance of the DPR the financial grant to set up the CFC is released to the SPV through the state government.

4.3 Various credit lines and bank schemes for financing of EE

There are several special lines of credit under which loans are provided to MSMEs at reduced rate of interest for adoption of clean and energy efficient technologies. SIDBI is the nodal agency for management and implementation of these lines of credit. More details related to existing credit lines and its scope of services is available with SIDBI. Some of these schemes are mentioned below.

- JICA - SIDBI financing scheme
- KfW - SIDBI financing scheme
- AfD - SIDBI financing scheme
- Sustainable Finance Scheme (SFS)

4.4 Preparation of detailed project report (DPR)

The guidelines to prepare DPRs for seeking loans from banks for the capital expenditures for implementing viable energy efficiency project are provided below.

Detailed financial analysis of the moderate to large investments is required as much for the promoter, as it is for the banker. The promoter is interested to see if the true return on the investment over the project life is comparable to returns on other sources of investment, such as a fixed deposit in a bank, while the banker needs to be convinced on the financial viability of the investment made through the loan. In general, each DPR on EE project is to be structured to include the company profile, energy baseline assessment, technology assessment, financial assessment and sustainability assessment.

The company profile of the unit will include assessment of its past financial reports (balance sheet, profit and loss account), registration details, compliance with pollution control board norms, as well as, details of products, production capacities, customers, and marketing and selling arrangements.

Similarly, the energy baseline assessment will include current energy bill, cost of energy as a percentage of total manufacturing cost, and overall and section-wise specific energy consumption levels.

Technology assessment will include the details of the design of equipment/ technology along with the calculation of energy savings. The design details of the technology for EE project will include detailed engineering drawing for the most commonly prevalent operational scale, required civil and structural work, system modification, and included instrumentation and various line diagrams. A list of vendors (technology providers/ equipment suppliers) will be provided along with quotations for major bought-out equipment. Examples of similar interventions as proposed in other industries within India or abroad with the benefits will also be provided. The estimated lead time for implementation of the new technology, or enhancement of the existing technology will be provided.

The financial assessment will contain details of investment required for each EE measure and means of financing for the proposed measures. Financial projects such as cost-benefit analysis for each of the proposed measure and for the unit as a whole including IRR and cash flow will be provided.

The sustainability assessment will include environmental and social sustainability assessments like Green House Gas (GHG) reduction (over the estimated lifetime in terms of certified emission reductions or CERs), reduction in conventional pollutants; air (sulphur dioxide, particulates etc.), water and solid waste, productivity enhancements and social impacts on the workforce.

A typical outline of the content page of a DPR is provided in table 4.4. It is understood that the DPRs will be structured keeping in view their acceptability to financial institutions/banks.

Table 4.4: Typical contents page of DPR

Executive Summary	
1.0	Introduction
1.1	Brief introduction about cluster/ unit
1.2	Energy performance in existing situation
1.3	Proposed EE intervention
1.3.1	Description of existing technology/ equipment
1.3.2	Energy audit methodology
1.3.3	Performance analysis of the existing technology
1.4	Barrier analysis in adoption of proposed EE intervention
2.0	Implementation methodology
2.1	Approach of modification
2.2	Description of modified system/ equipment
2.3	Availability of equipment
2.4	Source of equipment
2.5	Terms and conditions in sales of equipment
2.6	Process down time during implementation
2.7	Life cycle assessment and risks analysis
2.8	Suitability of unit for implementation of proposed technology
3.0	Benefits from proposed EE intervention
3.1	Technical benefit
3.2	Monetary benefits
3.3	Social benefits
3.4	Environmental benefits
3.5	Examples of similar interventions
4.0	Project Financial Statements
4.1	Cost of project and means of finance
4.2	Financial projections of the unit
4.2.1	Projected financial summary of the unit
4.2.2	Projected operating statement of the unit
4.2.3	Projected balance sheet of the unit
4.2.4	Projected cash flow statement of the unit
4.2.5	Projected fund flow statement of the unit
4.2.6	Projections of current assets and current liabilities of the unit
4.2.7	Debt Service Coverage Ratio
4.2.8	Debt Equity Ratio
4.2.9	Other major financial ratio calculations
4.2.10	Maximum permissible bank finance for working capital as per Nayak Committee
4.2.11	Working capital requirements
4.2.12	Assumptions for financial calculations
4.2.13	Marketing & Selling arrangement

4.2.14	Risk analysis and mitigation
4.2.15	Conclusion
Typical Appendices	
	Process flow diagram
	Baseline energy performance
	Schematic diagram of the modified system
	Technical specification and information brochure of equipment
	Details of fabricators/ suppliers
	Budgetary quotation for the proposed equipment
	Cash flow and financial analysis
List of used abbreviations	

4.5 Step by step approach for loan application

Energy efficiency projects are normally supported by banks and financial institutions under the broad umbrella of various government schemes and credit lines. These schemes and credit lines are formulated with specific eligibility criteria to promote special thematic issues for improving overall business sustainability of the target sector.

Loan application for EE projects is to be developed using standard format of individual scheme guidelines or credit line requirements. It is advisable for the concerned MSME unit to obtain the standard template of loan application from the prospective banking institute, which is going to evaluate loan application before granting financial support. The following activities are required to be undertaken for developing loan application to seek financial support from bank towards implementation of EE projects by the unit.

- Establish baseline performance through detailed study
- Identify implementable energy conservation measures (ECMs) including alternative energy efficient (EE) technologies wherever applicable
- Prepare preliminary cost-benefit analysis
- Identify suitable technology suppliers who can also provide regular maintenance
- Obtain techno commercial quotations
- Negotiate price and finalize suppliers
- Estimate miscellaneous costs for implementation of ECMs
- Estimate project cost and means of finance
- Undertake the financial projections of the unit
- Identify eligible financing scheme and credit line for financial support
- Discuss the EE project with the prospective financial institution (FI)
- Develop detailed project report as per the guidelines provided and format of the scheme that includes baseline monitoring and verification (M&V) protocol
- Submit the DPR to the FI for review
- Follow up with the FI and provide clarification if any
- Obtain loan approval and complete necessary contract with concerned FI

- Implement the project that includes commissioning, trial runs and troubleshooting required if any
- Undertake post implementation M & V protocol
- Submit status report to FI as per the agreement