

# **Comprehensive training material for Fabricators and maintenance operators Morbi Ceramic Cluster**

## **GEF-UNIDO-BEE Project Promoting Energy Efficiency and Renewable Energy in selected MSME clusters in India**

*Prepared for:*



Bureau of Energy Efficiency

## **©Bureau of Energy Efficiency, 2018**

This document has been originally prepared by TERI as a part of 'Capacity Building of LSPs' activity under the GEF-UNIDO-BEE project 'Promoting Energy Efficiency and Renewable Energy in selected MSME clusters in India'.

## **Suggested Format for Citation**

This document may be reproduced in whole or in part and in any form for educational and non-profit purposes without special permission, provided acknowledgement of the source is made. BEE and TERI would appreciate receiving a copy of any publication that uses this document as a source. A suggested format for citation may be as below:

GEF-UNIDO-BEE Project, Bureau of Energy Efficiency, 2018

“Capacity Building of Local Service Providers”

## **For more information**

GEF-UNIDO-BEE PMU

Bureau of Energy Efficiency

4th Floor, Sewa Bhawan, Sector-1,

R.K. Puram, New Delhi-110066

Email: [gubpmu@beenet.in](mailto:gubpmu@beenet.in)

[pmc@teri.res.in](mailto:pmc@teri.res.in)

Website: [www.beeindia.gov.in](http://www.beeindia.gov.in)

[www.teriin.org](http://www.teriin.org)

## **Disclaimer**

This document is an output of an exercise undertaken by TERI under the GEF-UNIDO-BEE project's initiative for the benefit of MSME units and is primarily intended to assist the decision making by the management of the intended unit for

the proposed technology. While every effort has been made to avoid any mistakes or omissions, GEF, UNIDO, BEE or TERI would not be in any way liable to any person or unit or other entity by reason of any mistake/omission in the document or any decision made upon relying on this document



# Contents

---

## About this manual

<b>1.0</b>	<b>Introduction.....</b>	<b>1</b>
1.1	Background .....	1
<b>2.0</b>	<b>Module 1 - Good practices in motor rewinding .....</b>	<b>3</b>
2.1	Reasons of motor failure.....	3
2.2	Overview of possible motor Losses .....	4
2.3	Best practices in motor rewinding .....	5
	List of references .....	14
<b>3.0</b>	<b>Module 2 - Energy efficient and Renewable Energy (EE/RE) technologies.....</b>	<b>15</b>
3.1	EE and RE technologies .....	15
3.2	Government Schemes and Policy .....	27
<b>4.0</b>	<b>Module 3 - Energy efficiency in Kiln and associated systems .....</b>	<b>29</b>
4.1	Drying Process and Equipment .....	29
<b>5.0</b>	<b>Module 4 - Best operating practices and O&amp;M in ceramic industries.....</b>	<b>41</b>
5.1	Best operating practices (BoPs) .....	41



## About this manual

---

This manual provides, in a direct and simple manner, guidance on improving energy efficiency for local service providers (LSPs) in the ‘Fabricators and maintenance operators’ category.

The aim is to build their capacities and equip them with the necessary knowledge and skills and to provide background information and tips regards energy efficiency (EE)/renewable energy (RE) options in important ceramic manufacturing process viz. Good practices in motor rewinding & electrical maintenance, Energy efficient and Renewable Energy (EE/RE) technologies, Energy efficiency in Kiln and associated systems and Best operating practices and O&M in ceramic industries.

The manual is designed to complement the knowledge shared with the participants through a series of four one day training/capacity building programs undertaken by TERI in Morbi Ceramic Cluster between March to June 2018 under the GEF-UNIDO-BEE Project “Capacity Building of Local Service Providers”.





# 1.0 Introduction

---

## 1.1 Background

The overall aim of the GEF-UNIDO-BEE project is to develop and promote a market environment for introducing energy efficiency and enhancing the use of renewable energy technologies in process applications in selected energy-intensive MSME clusters in India. This would help in improving the productivity and competitiveness of the MSME units, as well as in reducing the overall carbon emissions and improving the local environment.

The following three foundry clusters are targeted under the assignment - Coimbatore, Belgaum and Indore.

This comprehensive training material for Indore foundry cluster is targeted at 'Fabricators and maintenance operators, category. The material is structured in the following 4 modules.

Module 1	Good practices in motor rewinding & electrical maintenance
Module 2	Energy efficient and Renewable Energy (EE/RE) technologies
Module 3	Energy efficiency in Kiln and associated systems
Module 4	Best operating practices and O&M in ceramic industries



## 2.0 Module 1 - Good practices in motor rewinding

### 2.1 Reasons of motor failure

Electric motors fail for a variety of reasons. Certain components of motors degrade with time and operating stress. Electrical insulation weakens over time with exposure to voltage unbalance, over and under-voltage, voltage disturbances, and temperature. Contacts between moving surfaces cause wear. Wear is affected by dirt, moisture, and corrosive fumes and is greatly accelerated when lubricant is misapplied, becomes overheated or contaminated, or is not replaced at regular intervals. When any components are degraded beyond the point of economical repair, the motor's economic life is ended. The major cause of motor failure is shown in figure.



Power quality is one of the major issues leading to motor failure. Fluctuating/low voltage from the supply side (in LT industries) and voltage imbalance (due to major concentration of single phase loads) at the motor side are identified as the major reasons of on motor failure. This seems to be the cause of winding failure because of high winding temperature resulted by high current and subsequent insulation failure. Apart from the above, O&M practices like improper lubrication or/and defective bearing (selection and installation) also play role in winding failure. This is because of high inrush current in order to overcome the friction loss. It is highly felt that awareness creation must be done among the practicing engineers on how to reduce the chances of voltage imbalance at the motor end and frictional loss in motor bearings.

Poor housekeeping and cleanliness of workplace are also other reasons contributing to failure of the motor during operation in ceramic industries. The housekeeping activities like proper maintenance of motor inventories spare parts, cleanliness of name plates/motor body surface, proper ventilation and cabling, cleanliness of MCC panels and motor junction box are very important for healthy running of the motor. Apart from this quality of earthing are important areas which should not be ignored at the unit end. A poor earthing may not necessarily result in failure of the motor but is an important part of electrical safety. Best practices in



*Highest efficiency motors use thin laminations of high quality steel, coated with a microfilm of varnish and these were found to exhibit no increased loss over the test range of 350 – 400°C*

\*\*\*\*\*

*No load losses, stator copper losses are caused by heating from the current flow through the stator winding.*

*Techniques for reducing these losses include optimizing the stator slot design. Rotor losses are caused by rotor currents and iron losses.*

\*\*\*\*\*

*Replacement bearing & lubricants should be to the original specification and repairers should be aware that high efficiency motors*

housekeeping will certainly improve the motor health further in MSMEs cluster.

## 2.2 Overview of possible motor Losses

The loss in efficiency on rewinding depends on the techniques, processes and skill used to perform the rewind. Based on largely on a handful of studies of mostly smaller motors (up to 30 hp or 22.5 kW), they often assert that efficiency drops 1-5% when a motor is rewound-even more with repeated rewinds. It is usually between 1 and 2%.



In general, there are three factors affecting the efficiency of rewound motors

- ↪ **Increase in Iron Losses:** An increase in the iron losses can be caused
- ↪ **Mechanical stress in the core** will increase the hysteresis loss, as might happen if the core is fitted into a new frame with an undersized bore. The practice of hammering stator teeth back into place after stripping will result in increased hysteresis locally as a result of the residual stress. Eddy current loss will increase if the insulation between adjacent laminations is damaged, for example by burring together by filing or by accidental impact.
- ↪ **Thermal damage to the core:** thermal damage to the oxide or varnish insulation between the laminations is normally regarded as the usual cause of increased iron loss following a rewind. New work in which the increased loss after rewind under carefully controlled conditions for a number of motors was measured has shown that for conventional steels the temperature should not exceed 380°C. Losses increase very rapidly at higher temperatures.
- ↪ Most motors are designed to run with flux densities in the stator and rotor core just over the knee of the magnetisation curve. If the winding characteristics

are changed after rewind, for example if the numbers of turns are reduced, the flux density and hence the loss will increase.



**Copper Loss:** Stator copper loss is the largest loss (at full load) in most induction motors. The winding pattern may be changed during rewinding to simplify the process, and in doing so the repairer must consider the effect on flux density and resistance.

↳ These losses are reduced for example by increasing the size of the conductive bars and end rings to produce lower resistance. Stray load losses are the result of leakage fluxes induced by load currents. These can be decreased by improving slot geometry of rewound motors.

↳ **Mechanical Considerations:** The concentricity of rotor and stator is very important. It is common practice **to metal spray shafts or bearing housings** which have been damaged in service. This is acceptable only if special care is taken to preserve concentricity – errors which result in a minimum to **maximum gap ratio greater than 1:1.25** will adversely affect efficiency.

## 2.3 Best practices in motor rewinding

Most repair processes, if done improperly, can reduce motor efficiency. Conversely, doing them well will maintain and may even improve efficiency. It is also important to keep clear, concise written records throughout the repair process.

The following sections provide good practice procedures for each stage of the repair process, beginning with the preliminary inspection and dismantling the motors. The key recommended steps and standard/good practices is given in table below

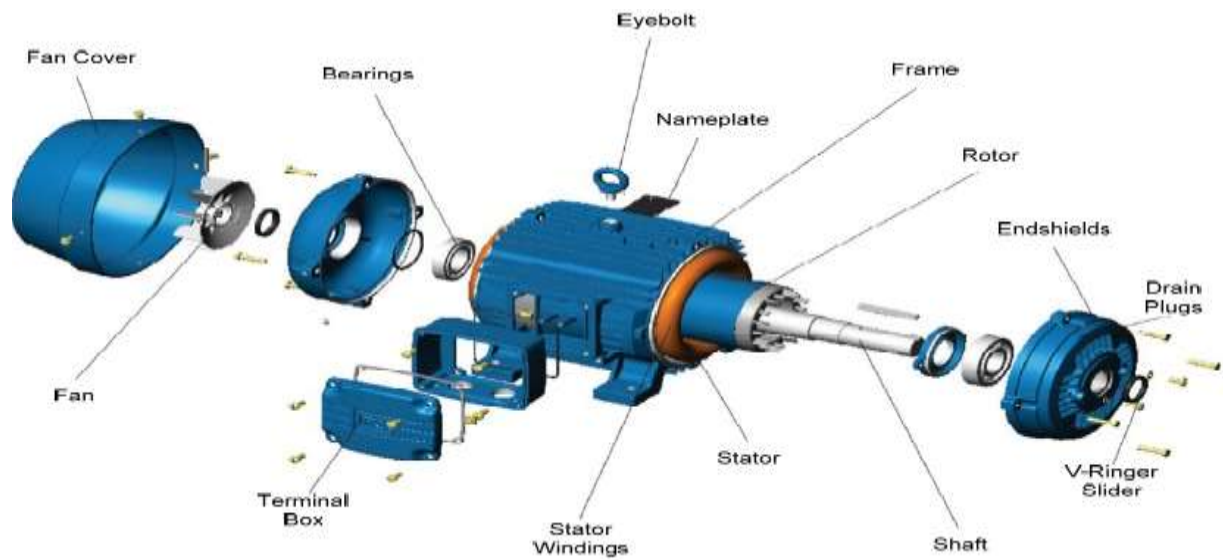

### STEPS OF REPAIR PROCESSES

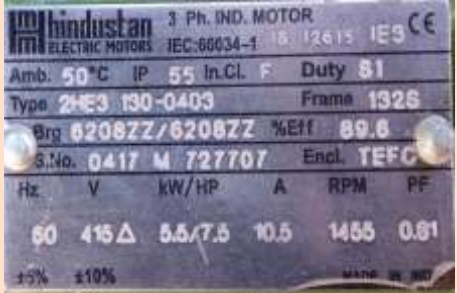

- Preliminary inspection
- Dismantling the motor
- Removing old winding
- Cleaning the core
- Rewinding the motor
- Reassembling the motor

Recommended procedure	Key steps	Observations
<p><b>Preliminary inspection</b> (The preliminary inspection forms an important part of the complete motor repair record and may yield vital clues about the cause of failure.</p> <p>Sometimes it is obvious from its outward appearance that the returned motor is not repairable and that a new one must be supplied. More often, however, the motor must be dismantled before this decision can be made.)</p>	<p>Motor nameplate(s) data</p>	<ul style="list-style-type: none"> <li>• Keep record of all data on the nameplate.</li> <li>• Check whether motor is IE efficiency class (as per IS12615).</li> </ul> 
	<p>Results of external inspection</p>	<ul style="list-style-type: none"> <li>• General condition—old/new, dirty/clean, etc.</li> <li>• Cooling air ducts clear/ obstructed – may have caused overheating.</li> <li>• Shaft discolored (brown /blue) – sign of rotor overheating or bearing seizure.</li> <li>• Parts missing, damaged or previously replaced/ repaired - e.g., seals, stator cooling ribs, fan, fan cover, terminal box, etc.</li> </ul>
	<p>User/Customer input</p>	<ul style="list-style-type: none"> <li>• Customers may be able to provide:</li> <li>• Operating environment – temperature, vibration, etc.</li> <li>• Type of driven equipment.</li> <li>• How many hours/day motor runs.</li> <li>• Approximate motor load.</li> <li>• How often it is started.</li> <li>• type of starter used</li> <li>• Rewinding history</li> <li>• How long the motor has operated since new (or since last rewind).</li> <li>• Unusual events—e.g., power outage, lightning strike, water damage, problem with driven equipment, etc.</li> </ul>
<p><b>Dismantling the motor</b> (It is essential to dismantle the motor carefully and to keep adequate records to ensure that if the motor is repaired it can be reassembled correctly. Place all parts that are not to be repaired in a suitable bin or</p>	<p>Terminal box position, layout and connections.</p>	<ul style="list-style-type: none"> <li>• Record markings on both winding leads and terminals.</li> <li>• Record positions of any links between terminals (make sketch).</li> <li>• Check that insulation on winding leads immediately adjacent to terminals does not show any signs of overheating (discoloration or</li> </ul>

Recommended procedure	Key steps	Observations
tray that is labeled with the motor serial number or job card number.)		brittleness). If it does, replace the leads. <ul style="list-style-type: none"> <li>• Confirm that all terminals are firmly crimped or brazed to winding leads.</li> <li>• Record size &amp; type of lead wire.</li> <li>• Record lug size and style.</li> </ul>
	Orientation of end brackets and bearing caps.	<ul style="list-style-type: none"> <li>• End brackets and bearing caps should be installed in exactly the same positions as originally fitted.</li> <li>• Mark all end brackets and stator frames at both ends of the motor (punch marking components with a center punch) before dismantling the motor</li> </ul>
	Bearing sizes, types and clearances.	<ul style="list-style-type: none"> <li>• Bearing enclosure</li> <li>• Fit and tolerance</li> <li>• Precision class</li> <li>• Internal clearance</li> <li>• Load application</li> <li>• Type of lubricant</li> </ul>
	Axial position of rotor relative to stator (drive end - DE or opposite drive end - ODE).	<ul style="list-style-type: none"> <li>• Rotor should be centered axially within the stator core.</li> <li>• If it is displaced axially, centering forces will exert pressure on the bearings.</li> <li>• If it is displaced beyond the end of the stator core, magnetizing current will increase.</li> <li>• Note position of axial thrust washer when dismantling the motor (i.e., DE or ODE).</li> </ul>
	Orientation of shaft with respect to the main terminal box.	<ul style="list-style-type: none"> <li>• Document the mounting position of the shaft in relation to the leads (F1 or F2).</li> <li>• There many ways to do this. Some repairers describe this as “leads left facing shaft” or “shaft right facing leads.”</li> </ul>
	Careful rotor removal to prevent damage to air gap surfaces or winding.	<ul style="list-style-type: none"> <li>• Rotor presents a considerable overhung load when one end bracket has been removed.</li> <li>• Allowing it to scrape along the stator bore during rotor removal can damage the air gap surfaces of both stator and rotor and increase losses. Winding damage can also result.</li> <li>• An effective way to remove and replace rotors in horizontal motors</li> </ul>



Recommended procedure	Key steps	Observations
		is by using a rotor removal tool
	Internal inspection	<ul style="list-style-type: none"> <li>• Water or dirt ingress.</li> <li>• Condition of stator and rotor cores–damage or overheating.</li> <li>• Condition of winding–discoloration, type of failure.</li> </ul>
	Mechanical damage to components or signs of misuse.	<ul style="list-style-type: none"> <li>• Damage to fan or fan cover</li> <li>• Damaged or blocked cooling ducts/channels/ribs</li> <li>• Shaft discoloration adjacent to either bearing (overload or misalignment)</li> </ul>
	Motors with contamination	<ul style="list-style-type: none"> <li>• If the exterior is packed full of contaminants, address maintenance procedures or consider a different enclosure.</li> <li>• If the winding is packed full of contaminants, the enclosure may not be suitable for the operating environment.</li> </ul>
<b>Removing the old winding and cleaning the core</b> (Although removal of old winding and cleaning core are necessarily carried out sequentially, recording the winding details is a coordinated activity carried out both before and during winding removal. Likewise, core loss testing is carried out at fixed points throughout the process.)	Recording the winding details on appropriate data cards or sheets	<ul style="list-style-type: none"> <li>• Winding configuration (lap, concentric, single, two or three layers, etc.)</li> <li>• Number of slots &amp; poles</li> <li>• Number of phases</li> <li>• Number, size &amp; marking of leads</li> <li>• Turns/coil</li> <li>• Grouping</li> <li>• Coil pitch &amp; Connections</li> <li>• Coil extension/overhang–connection end</li> <li>• Coil extension–non-connection end</li> <li>• Number and size of wires in each coil</li> </ul>
	Core loss testing	<ul style="list-style-type: none"> <li>• Make sure the tests are conducted well within the manufacturer’s recommended operating range for the tester being used. Carry out tests: <ul style="list-style-type: none"> <li>- Before burnout</li> <li>- After the core has been cleaned prior to rewinding.</li> </ul> </li> <li>• Remember that figures obtained are comparative, not actual losses.</li> <li>• If the core loss increases by more than 20%: <ul style="list-style-type: none"> <li>- Make sure the settings of the core loss tester have not been changed and repeat the test.</li> </ul> </li> </ul>

Recommended procedure	Key steps	Observations
		<ul style="list-style-type: none"> <li>- If the repeat test confirms the increased loss, repair the core or consider replacing it.</li> </ul>
	<p>Removing old winding</p> 	<ul style="list-style-type: none"> <li>• Step 1–Cut off one coil extension (usually opposite connection end): Cut off coil extension of the winding as close to stator core as possible without damaging the stator core.</li> <li>• Step 2–Remove the old stator winding: Varnish and insulation must be broken down before windings to be removed.</li> <li>• To be with a controlled temperature burnout oven. Coils must be heated sufficiently to burn out old insulation from windings without damaging interlaminar insulation.</li> <li>• It is important to set the oven temperature to monitor the temperature of the stator core. (See figure).</li> <li>• Key points–removing the old windings             <ul style="list-style-type: none"> <li>○ Cut off one coil extension using a winding cut-off machine.</li> <li>○ Burn out old insulation at appropriate temperature in a controlled-temperature burnout oven set to monitor core temperature.</li> <li>○ Do not overheat the core. Remove the winding without damaging the core.</li> </ul> </li> </ul>
	<p>Cleaning the stator core in preparation for rewinding</p>	<ul style="list-style-type: none"> <li>• Key points–cleaning the stator core:             <ul style="list-style-type: none"> <li>○ Careful scraping with a sharp</li> </ul> </li> </ul>

Recommended procedure	Key steps	Observations
		<p>knife.</p> <ul style="list-style-type: none"><li>○ High-pressure washing.</li><li>○ Blasting with a mildly abrasive material.</li><li>○ Brushing with medium/soft wire brush.</li><li>● After cleaning the slots:<ul style="list-style-type: none"><li>○ Reposition damaged teeth</li><li>○ Repair minor damage to air gap surfaces</li></ul></li><li>● Replace or reinsulate and rebuild cores if major damage has occurred</li></ul>

After performing the inspection and removal the winding, if choosing the replacement of winding the repairer has two options:

- Copy (duplicate) the winding already in the motor (provided it is the manufacturer’s original).
- Choose a different style of winding that will perform as well as or better than the original.

At this stage, the repairers have opportunity to redesign the motors to make them more energy efficient. Most of the time, however, the best way to maintain motor efficiency is to duplicate the original winding, while increasing the copper cross sectional area as much as possible and keeping the end turns as short as possible (certainly no longer than those of the original winding).

Though, that in some designs, the coil extension is critical for heat dissipation. If it is too short, the temperature of the winding may rise, causing I<sup>2</sup>R losses to increase.

When production volume justifies the cost, motor manufacturers use automatic coil winding and inserting machinery to produce motors with concentric coil groups. Repairers often find lap windings much quicker and easier to install.

This section therefore sets out the basic rules (in terms of maintaining efficiency) for just two types of rewind:

- A “copy” (or duplicate) rewind
- Changing the original concentric winding to a conventional lap winding

Recommended procedure	Key steps	Observations
<b>Rewinding the motor</b>	Copy (duplicate) rewinding	<ul style="list-style-type: none"> <li>• If the details of old winding have been recorded, and provided that it is the manufacturer’s original winding, the core can now be prepared for rewinding.</li> <li>• Even though the coil pitch (or pitches), turns/coil and the connections will be the same as those of the original winding, two changes could be made that will help to maintain or even slightly improve the efficiency of the rewound motor:                             <ul style="list-style-type: none"> <li>• Minimize the length of the coil extensions.</li> <li>• Increase the copper cross-sectional area in each coil.</li> </ul> </li> <li>• Key points–copy rewinding                             <ul style="list-style-type: none"> <li>○ Check that old winding is manufacturer’s original.</li> <li>○ Use same winding configuration.</li> <li>○ Keep coil extensions as short as practical.</li> <li>○ Same (preferably less) length of overhang.</li> <li>○ Use same coil pitch (or pitches).</li> <li>○ Use same turns/coil.</li> <li>○ Use same (preferably larger) copper cross-sectional area.</li> <li>○ Use same or shorter mean length of turn (MLT).</li> </ul> </li> </ul>

Recommended procedure	Key steps	Observations
		<ul style="list-style-type: none"> <li>○ Use same or lower winding resistance (temperature corrected).</li> </ul>
	<p>Minimize the length of the coil extensions</p>	<ul style="list-style-type: none"> <li>• It is important to keep the coil extensions as short as possible.</li> <li>• Attention to the following rules will prevent this:                             <ul style="list-style-type: none"> <li>○ Keep the coil extensions within the measured dimensions of the original winding.</li> <li>○ Do not extend the slot insulation beyond the slot ends any more than is necessary to prevent strain on the slot cell.</li> <li>○ Do not extend the straight portions of the coil sides any farther than is necessary to clear the slot insulation.</li> </ul> </li> <li>• Reducing the length of the coil extension will reduce the amount of copper in the winding and reduce losses.</li> </ul>
	<p>Changing to a two-layer lap winding</p>	<ul style="list-style-type: none"> <li>• Repairers often prefer to use lap windings because all coils are the same. This is acceptable if the new winding has the same flux/pole as the original.</li> <li>• Single-layer lap windings are sometimes used for small to medium-sized motors, because the coils are easier to insert and no separators are required. This allows more room for copper.</li> <li>• Double-layer windings distribute flux through the core better than single-layer windings. Replacing a double-layer winding with a single-layer winding will certainly reduce motor efficiency, so it is not recommended.</li> <li>• Lap windings should be appropriately short-pitched (i.e., the coil pitch must be less than the pole pitch unless the winding has only one coil per group).</li> </ul>
<p><b>Completing the winding</b> (After fully inserting the winding, connect the coils and leads to match the original connections exactly (if a copy or duplicate rewind) or appropriately for the replacement lap winding. Use connection leads that are as large as practical and mark all of them correctly. Brace the coil extension either as the manufacturer's original winding or better (i.e., more rigid). After checking</p>	<p>Winding resistance tests</p>	<ul style="list-style-type: none"> <li>• Measure resistance of first coil group wound and compare it with the calculated resistance. If possible, measure the resistance of a coil group from the original winding for comparison.</li> <li>• Measure the ambient air temperature (<math>T_a</math>) with the winding at room temperature. Correct both resistances to a convenient common reference temperature (normally 25°C) using the formula:</li> </ul>

Recommended procedure	Key steps	Observations
<p>the coil extensions a final time, perform winding resistance, insulation resistance, phase balance and voltage withstand tests)</p>		<div data-bbox="772 241 1362 546" data-label="Image"> </div> <div data-bbox="948 586 1305 645" data-label="Equation-Block"> <math display="block">R_x = \left( \frac{234.5 + 25}{234.5 + T_a} \right) \times \text{Measured resistance}</math> </div> <div data-bbox="896 645 1228 734" data-label="Text"> <p>Where  <math>R_x</math> = corrected winding resistance  <math>T_a</math> = ambient air temperature</p> </div> <ul data-bbox="715 748 1455 981" style="list-style-type: none"> <li>• The corrected value of resistance of the new coil group must be equal to or lower than that of the original coil group.</li> <li>• When the stator is fully wound, measure and record the resistance of each phase (or between leads) as well as the ambient temperature. Resistance of each should be equal within 5% (See figure)</li> </ul>
	<p>Phase balance (or surge comparison) tests</p>	<ul data-bbox="715 994 1455 1263" style="list-style-type: none"> <li>• Perform on completed winding before impregnation.</li> <li>• Test compares decay rate of identical voltage pulses applied simultaneously for 2 winding phases.</li> <li>• Trace pattern indicates phases identical (okay-identical traces) or different (fault-traces do not match).</li> <li>• Trace pattern gives guidance to type of fault (see equipment manufacturer's guide).</li> </ul>
	<p>Impregnation</p>	<ul data-bbox="715 1276 1455 1659" style="list-style-type: none"> <li>• Impregnating the winding with varnish and subsequently air drying or baking this varnish until it is cured serves the several purposes: <ul data-bbox="746 1397 1455 1585" style="list-style-type: none"> <li>○ It provides a mechanical bond between conductors.</li> <li>○ It increases the dielectric rating of the insulation.</li> <li>○ It protects the winding from moisture and contamination.</li> <li>○ It fills the air spaces between conductors (particularly in the slots).</li> </ul> </li> <li>• Lower winding temperature = lower resistance = lower I<sup>2</sup>R losses</li> </ul>

## List of references

International Copper Association India (Effect of Repair/Rewinding On Motor Efficiency © 2003, Electrical Apparatus Service Association, Inc.)

## 3.0 Module 2 – Energy efficient and Renewable Energy (EE/RE) technologies

---

### 3.1 EE and RE technologies

#### 3.1.1 Energy conservation of thermal energy

Considering the fuel reserves and increasing competition, it is essential to adopt energy conservation measures to improve overall efficiency, reduce operating cost/production cost and minimise the load on energy resources. The efficiency of a kiln will depend on how efficient the combustion system is and secondly how best the generated heat is utilized. Use of standard and good quality fuel improves overall performance of the firing system. Around 5 - 15% energy saving is possible from kilns used in ceramic industries. Some of the potential energy conservation measures (ECMs) for thermal system are listed below.

- Optimum kiln design to ensure capacity utilization to the tune of 98%
- Use of optimum product thickness to reduce heat load for sintering
- Complete combustion with minimum excess air.
- Proper heat distribution.
- Operating the kiln at desired temperature.
- Reducing heat losses from the openings.
- Minimizing wall losses by improving kiln insulation.
- Waste heat recovery from fuel gasses and utilization for drying green products
- Control of Chimney draught and kiln pressure
- Use pre-heating of spray dryer input slurry either solar or electrical heat pump
- Biomass / briquette firing in hot air generation
- Fuel switch over with better option in spray dryer
- Switching to continuous type kilns from intermittent type
- Adopting best operating practices including optimizing of excess air levels
- Use of hot air from cooling zone to preheat input material
- Energy efficient burner that can handle pre-heated combustion air at higher temperature
- Arresting air infiltration in kilns and spray drier system
- Use of lubricants and proper maintenance

Application of ECMs and absolute energy saving would largely depend on the base case scenario and relevant parameters likes operating efficiency of equipment, operating hour, operating load, landing fuel price etc. Some of the applications of ECMs are described below.

#### **Use of low thermal mass material in kiln fabrication and material movement**

Heavy refractory cars and saggars are generally used for carrying ceramic products inside the kiln. The dead weight of the refractories is quite high (around 24%). These refractories

which do not take part in reactions in formation of ceramic products, are subjected to alternate heating and cooling cycles, thereby losing substantial portion of heat input. These heavier refractory cars and saggars can be replaced effectively with low thermal mass cars and decker plates (23 – 24 % weight reduction is possible), which would help in reducing heat losses substantially. The estimated energy saving with use of low thermal mass cars is about 5-10%.

- Use of low thermal mass for kiln cart to **reduces the thermal weight** of the kiln considerably
- Weight reduction in kiln car saves significant amount of energy and also **improve material to car weight ratio**
- Reduces excess the **thermal energy storage** in the kiln furniture (**Roller**)
- Ultralite insulating material with supporting block gives proper support and increase the strength of the kiln base
- Replacing refractory bricks with hollow ceramic coated pipes at the supporting pillars for holding racks
- Dead weight can be cut down to 15 to 25% of the existing weight

#### Advantages of ultralite insulating material

- High open porosity
- Low thermal mass
- Low permeability
- Low thermal conductivity
- Low bulk density
- Lightweight



#### Maintain the required air to fuel ratio for proper combustion of fuel

Kilns are important segment in ceramic industries and accounting for about 50-65% of energy consumption. Various operating parameters such as temperatures, draft, retention time and material arrangement, etc. may vary with the type of kilns used. More the air is used to burn the fuel, more is the heat wasted in heating air. Air, slightly in excess of ideal stoichiometric (or theoretical) fuel to air ratio is required for complete combustion and to reduce NO<sub>x</sub> emissions; it is dependent on the type of fuel. However, excess air beyond the optimum range (an efficient natural gas burner however requires 2% to 3% excess oxygen, or 10% to 15% excess air in the flue gas, to burn fuel without forming carbon monoxide) may substantially decrease combustion efficiency as it leads to generation of excessive waste gases. The effect of excess air level and flue gas temperature on dry flue gas losses is shown in graph

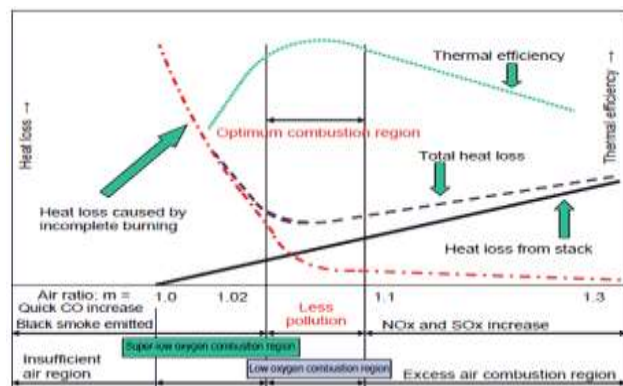



The relationship between the air-to-fuel ratio and wasted heat energy provides a basis for control system design. In most of the cases, real combustion processes have inadequate mixing of air with fuel. Also, the gases tend to flow so quickly that the air and fuel mix have limited contact time in the combustion zone. As such, if air is fed in exact theoretical or stoichiometric proportion to the fuel, it will still lead to incomplete combustion. Automatic burner assembly generally performs in a manner similar to the graph. The cost associated with operating at increased air-to-fuel ratio is the energy wasted in heating additional air volume. Yet, if the air-to-fuel ratio is decreased, losses due to incomplete combustion and emission will increase rapidly.

Kiln thermal parameters controller comprises kiln temperature, pressure and atmosphere controlling. In different stages, the control act differently, in firing process, PLC control inverter adjust the combustion fan to change air flowing in air hose. Electric valve of fire nozzle is set by numerical program to setup kiln atmosphere during heating process.

In the cooling stage, NG is shut down and each fire valves/nozzle is closed automatically. The temperature controller switch to the cooling control mode and the system enters cooling stage. In this period, air general pipe is controlled by opening degree.

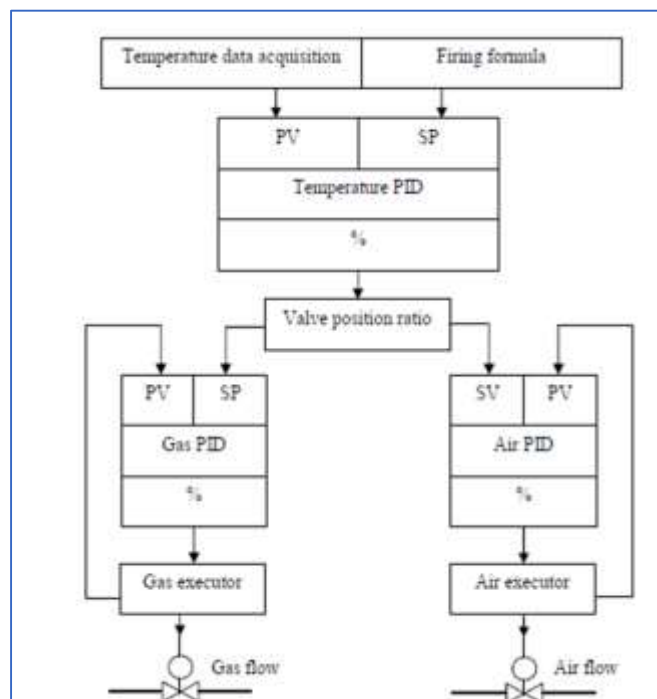

Fire nozzles are divided into two groups. In order to reduce cost, temperature valve position automatic control is used as shown in Figure. Each gas general hose has gas solenoid valve and each group of gas general hose and combustion general hose is installed with electric executor. This compares the air-fuel ratio practical value (PV measured by thermocouples) with set value (SV) and controls gas executor and combustion executor by PID regulator. Temperature PID controller controls firing by controlling air flow and gas flow which are accomplished by the opening degree of combustion air valves and gas valves. The benefits of combustion control system will be:

- Reduce excess fuel consumption.
- Reduce blower power consumption
- Increases exhaust temperature
- Give higher benefits in preheated combustion air as well as in dryer applications

Reduction of the excess air flow rate leads to a reduction in kiln energy consumption, though this operation must be performed with care, because other kiln operating parameters could be affected. It has been experimentally verified that 2% reduction in the oxidising air flow rate entails a decrease of the order of 5% in the natural gas flow rate.

(Source: Manual on Energy Conservation Measures in Ceramic Industry, BEE SME Programme)

### Improved insulation of kiln

The heat loss from a kiln structure can be divided into (i) radiation loss through openings and surface of the body, (ii) heat accumulation loss to internal insulation and supports composing the body. Improvement in the radiation heat loss from surfaces can be achieved by reinforcing its insulation. This includes (i) covering of internal wall surface with ceramic fibre insulation, and (ii) covering external wall surface with ceramic fiber or rock wool insulation.

The temperature gradient i.e. difference between the hot face temperature (hot face temperature is the temperature of the surface in contact with the flue gas or heated combustion air) and surface temperature will be a critical factor for reduction in heat loss by reinforcement of insulation. The hot face temperature is used to determine refractory or insulation thickness and heat transmitted. The design temperature is used to specify the service temperature limit of refractory materials.

The potential energy savings for insulating the firing zone of kiln may be up to 2-5%. However the capital investment required for reinforcement of insulation may be higher

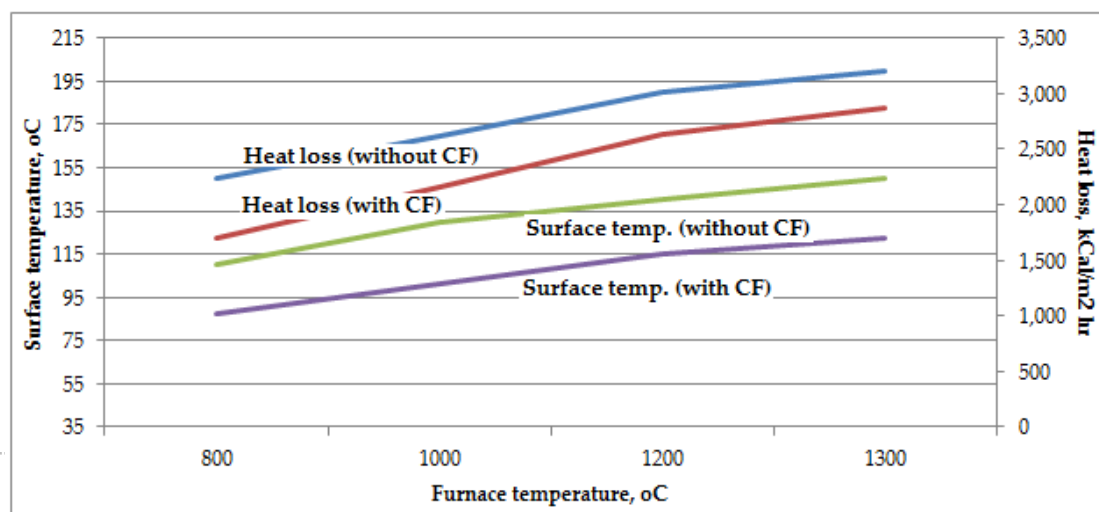
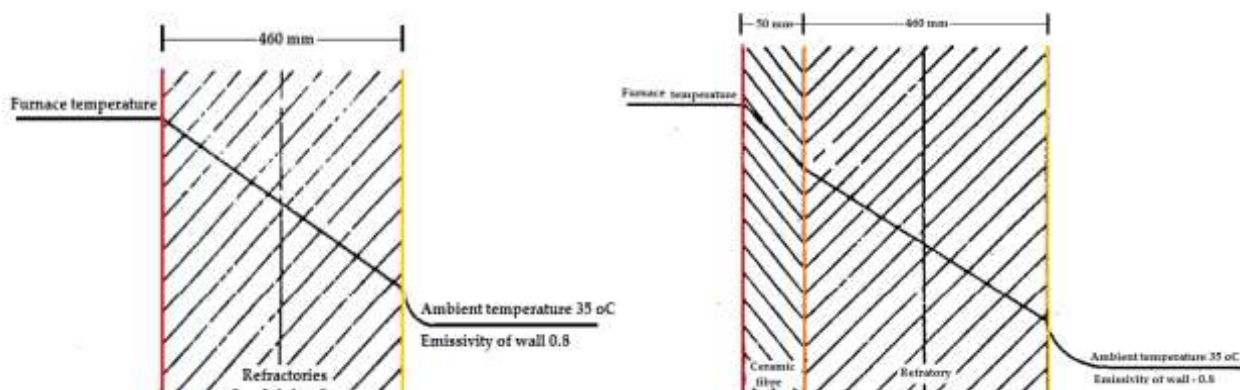

Effect of insulation in a kiln: Heat loss vs surface temperature

indicating long payback period.

### Use of hot air of cooling zone of kiln directly as a combustion air

Hot air from cooling zone of kiln has a temperature of about 250-300 °C. Use of this hot air directly for combustion of fuel (NG or PG) can result in significant savings in fuel consumption in the kiln.

(Source: Manual on Energy Conservation Measures in Ceramic Industry, BEE SME Programme)

### Use of energy efficient & high preheated air temperature burners

Use of high velocity energy efficient burner's and high preheated air temperature burners further improves kiln efficiency. Observed maximum preheated air temperature in the kiln in Morbi cluster is 250 °C, whereas current burner technology accepts air preheat temperature upto 600 °C. This offers good opportunity for high temperature waste heat recovery. Higher the combustion air temperature, lower will be the fuel consumption in the kiln.

(Source: Manual on Energy Conservation Measures in Ceramic Industry, BEE SME Programme)

### Energy conservation of electrical energy

Share of electrical energy consumption may be less but absolute quantity is very high. There are cost effective feasible measures, which could reduce energy consumption in ceramic industries. Some of the potential ECMs to save electrical energy are mentioned below.

- Continuous multi-stage or vibro ball milling system to replace conventional ball milling / blunger
- Installation of load sensor on conveyor belt to control auto on off depending upon the load availability on the belt
- Energy efficient motors with VFD for variable load applications or demand fluctuates like ball mill, blunger, agitating tank, dedusting and centralize vacuum cleaning, compressor, belt conveyor etc.
- Cogeneration system to reduce electrical as well thermal energy consumption
- Automatic hydraulic press system with interfacing and interlocking to switch off chiller system when hydraulic press is non-operative
- avoid idle operation of hydraulic press pump
- Auto interlock between brushing dust collection blowers and glazing lines
- Energy efficient utilities and lighting system
- Switch over electrical heating system to low cost primary fuel heating system
- Sensor based intelligent water tap
- Level controller for water pumping system for auto on -off

Some of the applications of ECMs are described below.



### Application of energy efficient motors & VFDs

Generally, most of the existing motors in ceramic industries are age old and very inefficient due old model apart from wear and tear in use. The electrical energy conservation measures in a ceramic unit include use of energy efficient motors in polishing area, replacement of smaller motors with a single large motor, adopting energy efficient motors and VFD (variable frequency drives) in agitating tanks, material conveyor, spray dryer, kiln blower, press and compressor sections and use of energy efficient hydraulic pumps. These measures would help in achieving energy saving between 8-15%.

### Replacement of V belts by energy efficient flat belts

Replacement of V-belts with flat belts or grooved V-belts can typically save 4-6% of the transmitted energy. There is potential for these savings in ball mills & agitators.

(Source: *Manual on Energy Conservation Measures in Ceramic Industry, BEE SME Programme*)

### Energy efficiency in compressed air system

Compressed air is used widely in ceramic industry and is often considered the “fourth utility” at many facilities. It is further extremely inefficient at part load. Improving and maintaining compressed air system performance requires not only addressing individual components, but also analyzing both the supply and demand sides of the system and how they interact. Various energy saving opportunities to optimize the compressed air use and electricity consumption are as follows:



Supply and demand sides of compressed air system

**Review air demand:** Before taking initiatives to improve the compressed air system, it is necessary to determine the air demand or requirements of the manufacturing facility. To obtain demand profile, the air delivery from compressor section must be measured at various points over a period of time (to take care of load variations). It is also necessary to monitor system pressure and power consumption at the same points and time in order to see how the flow, pressure and power consumption change over time. This profile should be obtained over a typical production cycle so that demand on compressed air system can be seen at all stages.

The air compressors provided in rolling industries mainly use load/unload mode (online/offline control) of operation. During unload condition, it keeps the motor running continuously, but unloads the compressor when the discharge pressure is adequate. Unloaded power consumption of air compressor is significant of their full load power

demand (Screw: 30-40% and Reciprocating: 15 -20%), while producing no useful compressed air output.

To minimize the electricity consumption during unload, variable speed option is an appropriate solution. VSD enabled compressors should be considered for trim (or swing) duty as they are typically the most efficient control mechanism to cater to partial loads. Capable of supplying a constant pressure through a wide control range, energy consumption and flow of a VSD compressor is almost directly proportional to the speed. This can result in energy savings over comparable fixed speed units when compressors are partially loaded.

**Pressure profile:** Higher the generation pressure of compressed air, higher will be the power consumption. Different tools and process operations require different pressures. Required pressure levels must take into account system losses from dryers, separators, filters, and piping.

*A rule of thumb, for every 2 psi increase in discharge pressure, energy consumption will increase by approximately 1 percent at full output flow.*

There is also another penalty for higher-than-needed pressure. Raising the compressor discharge pressure increases the demand of every unregulated usage, including leaks, open blowing, etc.

*Set pressure = maximum pressure required at end use + minimum pressure drop*

**Compressed air system leaks:** Compressed air leaks can be a significant contributor of wasted energy in a compressed air system, and in some instances lead to productivity losses. It is not unusual to encounter 20-40% of a compressor’s output as air leaks in typical industrial facilities. Although leaks can occur in any part of the distribution system, the most common areas/ points of leaks include couplings, hoses, tubes, fittings, pipe joints, quick disconnects, filters, regulators, lubricators, condensate traps, valves, flanges, packing, thread sealants and points of use devices.

Leakage rates are a function of the supply pressure in an uncontrolled system and increase with higher system pressures. Leakage rates are also proportional to the square of the orifice diameter (refer table). Proper installation and preventive (detection and repair) maintenance of compressed air distribution network and associated system can reduce leaks to less than 10% of a plant’s compressed air generation.

Leakage rates* (cfm) for different supply pressure and approximately equivalent orifice sizes						
Pressure (psig)	Orifice Diameter (inches)					
	1/64	1/32	1/16	1/8	1/4	3/8
70	0.3	1.2	4.8	19.2	76.7	173
80	0.33	1.3	5.4	21.4	85.7	193
90	0.37	1.5	5.9	23.8	94.8	213
100	0.41	1.6	6.5	26.0	104	234
125	0.49	2.0	7.9	31.6	126	284

\*For well-rounded orifices, multiply the values by 0.97, and for sharp-edged orifices, multiply the values by 0.62.

In addition to being a source of wasted energy, leaks can also be reasons to other operating losses. There is strong “cause and effect” relationship between the number and magnitude of air leaks with the overall compressed air system pressure. For example, lower air pressure can affect air tools and equipment by reducing the mechanical output and decreasing the productivity.

An ultrasonic leak detector is probably the most appropriate equipment to detect air leakages. An ultrasonic sensor focuses on the ultrasonic elements in the noise. Because ultrasound is a short wave signal, the sound level will be loudest at the leak site. These detectors are generally unaffected by background noises in the audible range because these signals are filtered out.

### Energy efficiency in pumps

Pumps are used mainly in the finishing section of the ceramic industries (except sanitary ware). Inefficient operation of pumping system can be caused by a number of problems such as improper pump selection, poor system design, excessive wear-ring clearances and wasteful flow control practices. Indications of inefficient system operation include high energy costs, excessive noise in the pipes and across valves and high maintenance requirements. Each pump has a best efficiency point (BEP) at which its operating efficiency is the highest and its radial bearing loads are lowest (except for pumps with concentric case designs). At its BEP, a pump operates most cost-effectively in terms of both energy efficiency and maintenance. Operating a pump at a point well away from its BEP may accelerate wear in bearings, mechanical seals and other parts. In practice, it is difficult to keep a pump operating consistently at this point because systems usually have changing demands. However, keeping a pump operating within a reasonable range of its BEP lowers overall system operating costs.

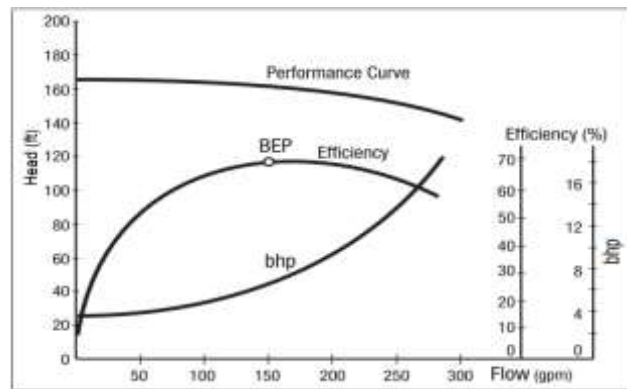

Best efficiency point in pump operation

Another critical criterion to maintain the efficiency of pump is speed. The pump speed is usually an important consideration in system design. It is perhaps best determined by evaluating the effectiveness of similar pumps in other applications. In the absence of such experience, pump speed can be estimated by using specific speed which can be used in two different references: impeller specific speed and pump suction specific speed.

The energy efficiency methods which can be used to maintain the efficiency in pumps without replacement are given below.

**Impeller trimming:** Impeller trimming refers to the process of machining the diameter of impeller to reduce the energy added to the system fluid. It can be a useful correction to pumps that, through overly conservative design practices or changes in system loads, are oversized for their application. The industry may consider trimming of impeller while any of the following conditions occur:

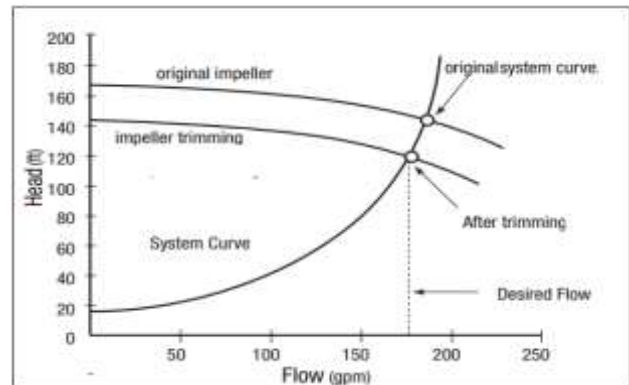

Effect of impeller trimming

- Many system bypass valves are open, indicating that excess flow is made to system equipment
- High levels of noise or vibration indicate excessive flow
- Excessive throttling is needed to control flow through the system or process
- A pump is operating far from its design point.

*Trimming an impeller changes its operating efficiency, and the non-linearities of the affinity laws with respect to impeller machining complicate predictions of pump performance. Consequently, impeller diameters are rarely reduced below 70% of their original size.*

**Adjustable Speed Drives:** Centrifugal pumps are often operated over a wide range of conditions. For example, many process cooling systems experience variable loads caused by changes in ambient conditions, product shape & size and production demands. To accommodate demand changes, flow can be controlled by any of these four methods - bypass lines, throttle valves, multiple pump arrangements or pump speed adjustments. The pump characteristics and loss in power due to throttling and bypass mechanism is shown in figure.

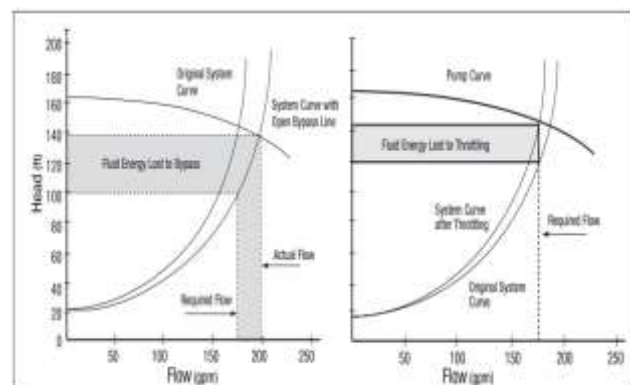

Pump characteristic curve

To maintain the desired flow rate efficiently, speed adjustment is the most efficient means of control. Reducing the pump speed means less energy is imparted to the fluid and less energy needs than the throttling or bypass method. There are two primary ways of reducing the pump speed: using

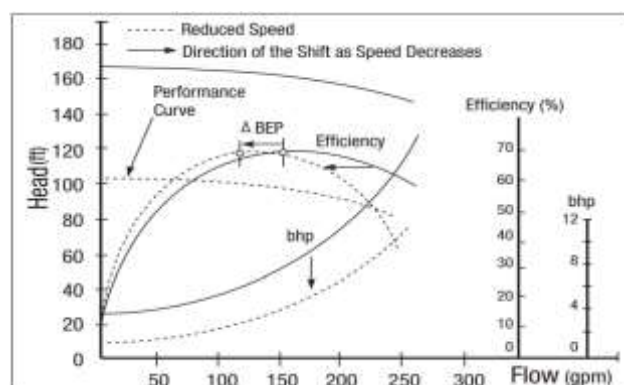

Characteristic curves with ASD

multiple-speed pump motors and using adjustable speed drives (ASDs). The ASDs allow pump speed adjustments to be made over a continuous range, avoiding the need to jump from one speed to another. ASDs control pump speeds using different types of mechanical and electrical systems. Mechanical ASDs include hydraulic clutches, fluid couplings, and adjustable belts and pulleys. Electrical ASDs include eddy current clutches, wound-rotor motor controllers and variable frequency drives (VFDs). VFDs adjust the electrical frequency of the power supplied to a motor to change the speed.

**Energy efficient centrifugal pump:** Centrifugal pumps handle high flow rates, provide smooth, non-pulsating delivery, and regulate flow rate over a wide range without damaging the pump. Centrifugal pumps have few moving parts, and hence the wear caused by normal operation is minimal. They are also compact and easily disassembled for maintenance. The design of an efficient pumping system depends on relationships between fluid flow rate, piping layout, control techniques, and pump selection.

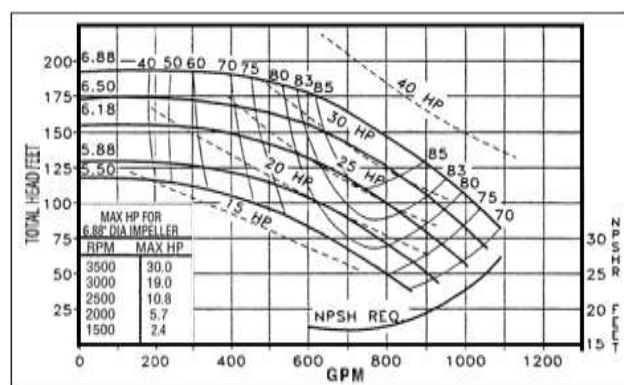

Characteristic curves for centrifugal pumps

Before selection of a pump, it is necessary to examine its performance curve, which is indicated by a head - flow rate or operating curve. The curve shows the pump capacity (flow rate) against total developed head. It also shows the design efficiency, required input power and suction head requirements (net positive suction head requirement) over a range of flow rates. Pump curves also indicate pump size and type, operating speed and impeller size. It further shows the best efficiency point (BEP). The pump operates most cost effectively when the operating point is close to the BEP.

To minimize energy consumption, the pump should be selected in such a manner that the system curve intersects the pump curve within 20% of its BEP. The impeller of the pump should be selected in the mid-range; it can be trimmed or replaced to meet higher or lower flow rate as per requirements.

**Energy efficiency in distribution transformers**

After transmission and distribution of electrical energy, facility level distribution transformers represent the next highest source of energy losses. Distribution transformers are relatively easy to replace and manage (in comparison with other technologies used in industrial facilities), and the efficiency can be easily measured and sustained. Taking life cycle cost into account, installation of high efficiency transformers is an economically sound



investment despite higher initial cost. Other benefits include reduced emissions, improved reliability and potentially longer service life.

▪ **Ultra-high efficiency transformers:**

Transformers are continuous operating system for any facility and therefore reduction in losses is a matter of importance. The development in transformers in last decade has led to the appearance of ultra-high efficiency transformers, which have lower energy losses as compared to conventional transformers. To reduce the iron losses (no-load losses), following iron core material technologies have been developed:

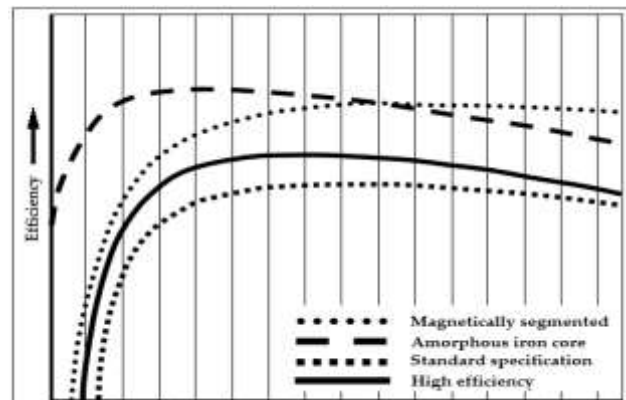

Efficiencies of ultra-high efficiency

To reduce the iron losses (no-load losses), following iron core material technologies have been developed:

- High-orientation silicon steel sheet
- Laminated iron core of thinner silicon steel coil material
- Magnetically segmented silicon steel coil sheet
- Amorphous iron cores

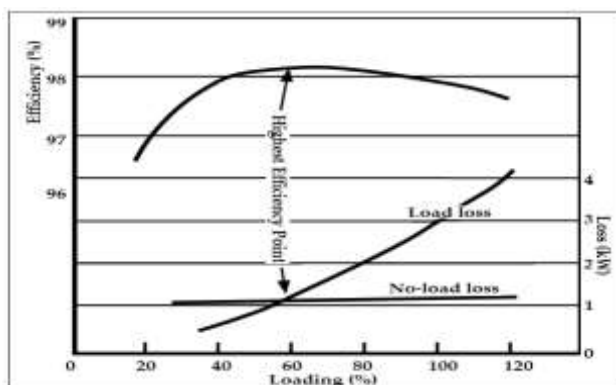

No-load and load losses in transformers

With the use of efficient iron core materials, a no-load loss reduces considerably in comparison to transformers using conventional core material. Other advantages of ultra-high efficiency transformers include no fire risk, no risk of escape of pollutants or fire-hazardous substances, long lifetime, high mechanical strength and reduced emissions.

**Power management system / transformer quantity controller:** There are two types of transformer losses, i.e. no-load loss and load loss (copper loss). The no-load losses are certain amount of losses regardless of the existence of load on the transformer. If there are one or more transformers with same primary and secondary voltage, the total losses may be optimized by shifting the load of low load transformer to other transformer.

To achieve the maximum benefits of parallel transformer system, PLC based power management system (PMS) may be adopted. The transformer can be operated with highest possible efficiency

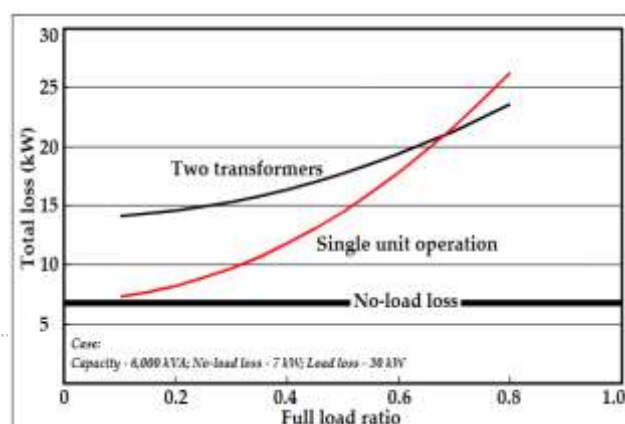

Parallel operation of transformers

when the no-load loss and the load loss become equal. Therefore, if one or more transformers are operated in parallel and if the load is fluctuating, PMS controls the losses by adhering to efficiency characteristic of each transformer and automatically controls the number of transformers and the combination of the transformers required according to the load fluctuation.

### Lighting system

In ceramic units, energy consumption for illumination also has considerable share. Typical method to optimize energy use in lighting may be upgradation of existing system or adoption of new and efficient technologies. The use of automation in the existing facility may save up to the extent of 50% of energy use by providing the right amount of light. These control system can also help to provide safer,

more productive work environment. High efficiency lamps and ballasts, new and efficient light technologies (LED, Induction lamps, compact fluorescent lamps etc.) and use of reflectors may lead to significant reduction in operational cost.

Product	The initial purchase cost for the lighting system	Beyond first cost, compare performance: service life, lumen maintenance, and color rendering and stability
Energy	Annual operating hours multiplied by electrical cost	Consider product wattages as well as light output & lamp performance
Maintenance	Includes manpower and relamping costs	Longer-life lamps that maintain colour stability and lumen output can reduce maintenance
Disposal	The end-of-life cost, including disposal and recycling of lamps, ballasts and fixtures	Another area where longer-life lamps benefit industrial facility owners, by reducing waste and cost

**Lighting control:** Quality lighting is an important aspect in steel rolling industries, and is often an ignored area. Light control has the ability to regulate the level and quality of light in a given space for specific tasks or situations. The lighting control systems include timer and inverter based dimmer control systems to optimize the use of daylight operation. Optimum control of task specific lighting not only enhances the comfort level of work stations but it also helps to save energy by using light when and where it is needed most.

Lamp type	Lumens per watt	Rated life (hours)	Color rendering index, CRI	Color temperature, °K
T8 high-performance fluorescent with electronic ballasts	86 – 96+	24,000 to 42,000+	80 to 85	3,000 to 6,500
T5 with electronic ballasts	86 – 96+	30,000 to 40,000	80 to 85	3,000 to 5,000
T5HO with electronic ballasts	86 – 96+	30,000 to 40,000	80 to 85	2,700 to 5,000
Compact fluorescent lamps (hard-wired)	43 – 71	6,000 to 12,000	80 to 85	2,700 to 5,000
LED replacement lamps	50 – 100+	25,000 to 50,000+	80 to 90+	2,700 to 6,000+
LED, new fixtures	Up to 100+	50,000 to 100,000	80 to 90+	2,700 to 6,000+
Electronic HID	60 – 80	20,000	85 to 90	2,900 to 4,000
Induction (filament less)	60 – 75+	100,000	80 to 90+	3,000 to 4,000+

**High efficiency lighting:** Recent technological advancements have introduced a new era of energy efficient lighting products. Replacement of the existing lighting with most advanced light sources and fixtures may save upto 50% on lighting energy use, while benefiting from the best in lighting quality. Energy efficient lighting offers additional benefits such as reduced load on air conditioning and ventilation system, better life and is compatible with advance control & automation.

### 3.1.2 Adoption of renewable energy

#### Preheating slurry using solar dryer/ heat pump

The slurry entering spray dryer is generally enters at ambient conditions. The slurry can be preheated using solar dryer or heat pump which would help in reducing the energy consumption in spray dryer by about 5%.

#### **Rooftop solar system**

Solar Power, a clean renewable resource with zero emission, has got tremendous potential of energy which can be harnessed using a variety of devices. With recent developments, solar energy systems are easily available for industrial use with the added advantage of minimum maintenance. The average solar irradiation in Gujarat state is 5.82 kWh/m<sup>2</sup>/day and Uttar Pradesh is 4.27 kWh/m<sup>2</sup>/day.

A grid connected photovoltaic system will be interacted with utility grid. The main advantage of this system is that power can be drawn from the utility grid and when power is not available from grid, PV system can supplement that power. These grid connected systems are designed with battery or without battery storage. These systems consist of the following:

- Solar panels mounted on the roof or in open spaces. Photovoltaic modules produce direct current (DC) electrical power.
- Batteries to store DC energy generated by the solar panels.
- Charge controller to prevent overcharging the battery.
- Specially designed inverter to transform the PV generated DC electricity to the grid electricity (which is of AC) at the grid voltage.

## **3.2 Government Schemes and Policy**

### **3.2.1 Credit Linked Capital Subsidy Scheme (CLCSS)**

The objective of the Scheme is to facilitate technology up-gradation in MSEs by providing an upfront capital subsidy of 15 per cent (on institutional finance of upto Rs 1 crore availed by them) for induction of well-established and improved technology in the specified 51 subsectors/ products approved. In other words the major objective is to upgrade their plant & machinery with state-of-the-art technology, with or without expansion and also for new MSMEs which have set up their facilities with appropriate eligible and proven technology duly approved under scheme guidelines. List of Technologies is available at [www.dcmsme.gov.in](http://www.dcmsme.gov.in)

(Source: [http://www.dcmsme.gov.in/schemes/credit\\_link\\_scheme.htm](http://www.dcmsme.gov.in/schemes/credit_link_scheme.htm))

### **3.2.2 Credit Guarantee Fund Trust for MSE**

This scheme will cover both term loan and working capital facility upto Rs.100 lacs. Under this scheme, loan will be sanctioned without any collateral security or third party guarantee. For more details of the scheme visit [www.cgtmse.in](http://www.cgtmse.in)

(Source: <https://www.cgtmse.in>)

### 3.2.3 Technology Up-gradation Scheme for Micro Small and Medium Enterprises (MSMEs)

The first objective of the scheme is to sensitize and encourage the manufacturing MSME sector in India to the use of Energy Efficient Technologies and Manufacturing Processes so as to reduce cost of production and emissions of GHGs.

The second objective of the scheme is to create awareness and encourage the MSMEs to acquire Product Certification/ Licenses from National/ International Bodies.

(Source: <http://www.dcmsme.gov.in/schemes/TEQUPDetail.htm>)

### 3.2.4 Assistance for Saving in Consumption of Energy & Water (Gujarat state)

- The existing as well as new enterprise taking action for saving in consumption of Energy and Water will be eligible for assistance under this scheme
- The Enterprises which are registered as an industrial unit under MSME Development act, 2006 with respective DIC are eligible to get benefit
- 75% cost of energy/water audit conducted in a unit by a recognized institution/consultant subject to a limit of Rs. 50,000.
- 25% of cost of equipment subject to maximum Rs. 20 lakhs per project. Only one time assistance will be eligible during the operative period of the scheme

(Source: <https://ic.gujarat.gov.in/assistance-for-saving-in-consumption-of-energy.aspx>)

## 4.0 Module 3 – Energy efficiency in Kiln and associated systems

### 4.1 Drying Process and Equipment

In the process of ceramic manufacturing, the major energy is drawn into the drying process and its associated auxiliaries. The thermal energy used in the drying process is primarily from natural gas. Other than the thermal energy, electricity is also used in driving the associated auxiliaries such as fans, blowers and material handling systems. In a ceramic manufacturing process, the thermal energy share is about 60-70%, whereas the electrical share is about 30-40%. Thus, it is very essential to adopt automation and new and energy efficient technologies/practices to optimise the cost of operation as well as minimising the emissions.

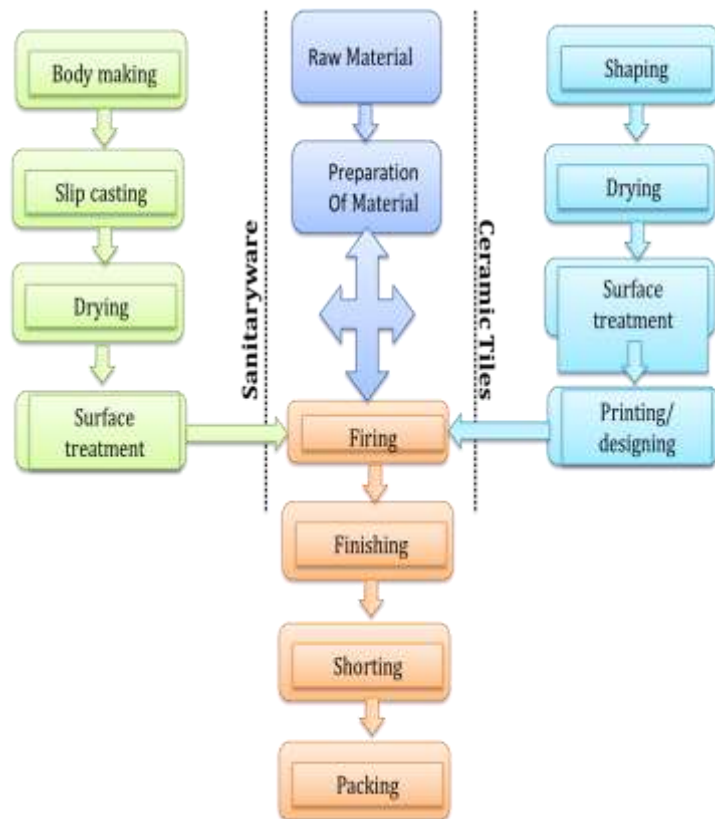

In the ceramic clusters, mainly tunnel kiln and roller kiln are employed. In sanitaryware manufacturing, pusher type tunnel kilns are most common and in tiles manufacturing, roller kilns are installed.

#### 4.1.1 Types of kilns

##### Tunnel kiln

Tunnel kiln is a continuous moving ware kiln in which the clay products to be fired are passed on cars through a long horizontal tunnel. The firing of products occurs at the central part of the kiln. The tunnel kiln is considered to be the most advanced ceramic and brick products making technology. The main advantages of tunnel kiln technology lay its ability to fire a wide variety of clay products, better control over the firing process and high quality of the products.

The tunnel kiln is, as the name shows, a narrow and long tunnel having the rails in both sides at the bottom. The wares loaded on the kiln cars are charged through the entrance of the tunnel and route continuously through the pre-heating, firing and cooling zones, and then discharged from the exit as shown in figure

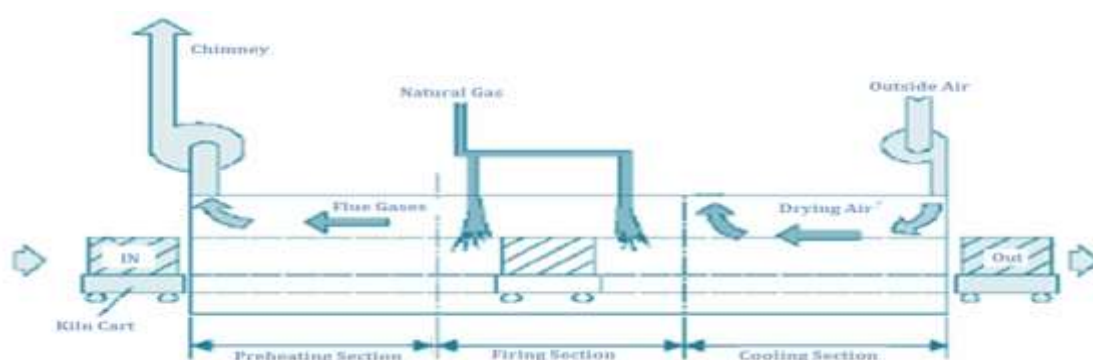

The combustion gas and air always flow from the kiln exit to the entrance such that the adjustment of one firebox affects not only the firing zone but also the pre-heating zone. Especially at reducing firing, the adjustment requires the most care and experience considering various factors; the border of oxidizing and reducing zones and that of reducing and neutral zones, the effect of cooling air to firing zone, the relation between the temperature and atmosphere in reducing zones, etc.

In such type of kilns heavy refractory carts and saggars are generally carry ceramic products through the different temperature zones of the kiln. These carts are generally heavy carts made up of refractory materials which do not take part in any reactions in formation of ceramic products, are subjected to alternate heating and cooling cycles. The general specifications of tunnel kiln commonly used in sanitary ware manufacturing process are given in table below.

Parameters	Units	Type - 1	Type - 2	Type - 3
Internal kiln width	m	2.62	3.04	3.45
Useful car width	m	2.42	2.83	3.23
Car length	m	1.4	1.4	1.4
Useful car length	m	1.38	1.38	1.38
Useful loading height	m	0.8-1.1	0.8-1.1	0.8-1.1
Useful car area	m <sup>2</sup>	3.35	3.92	4.48
Kiln length	m	45-90	45-100	60-110
Maximum temperature	oC	1350	1350	1350
Indicative firing cycle	Hours	10-14	10-14	10-14
Indicative specific consumption	Kcal/kg	1100-1300	1100-1300	1100-1300

### Roller kiln

In such type of kiln the product movement is governed through silicon carbide based roller. It is a continuous kiln where in the product flow is continuous though different temperature zones. Controlling of is mostly though temperate based controlled installed in different temperature zones.

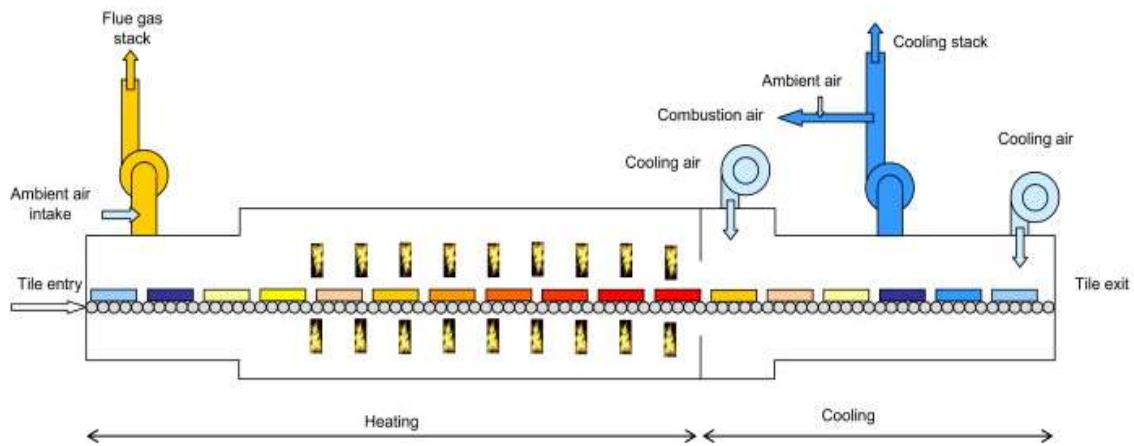

In ceramic tiles manufacturing process, there are different types of kilns but the most appropriate and the most efficient kiln is the roller kiln. This type of kiln is continuous firing kiln with ceramic rollers which transport ceramic tiles at different firing temperature with uniform temperature distribution. Usually the temperature in the inlet does not vary significantly with the outlet of the preheating zone and the temperature is usually highest at its 3<sup>rd</sup> quarter's section. The temperature of the kiln outlet is also control to prevent thermal shock which may result to breakage of resulting tiles.

**Table 5.1.1:** Basic kiln details

Parameters	Units	Type 1	Type 2
Maximum temperature	°C	1250	1250
Channel width	m	2.6	2.85
Optimum load width	m	2.36	2.6
Indicative length	m	65-180	75-200

### 4.1.2 Heat balance of kiln

Heat balance of the kiln is a mean to determine the thermal efficiency of the system and compare the relative heat losses. By making comparison with an identical process, areas of inefficiency can be identified, where a change in operational control or equipment could lead to improvement in thermal efficiency of the kiln.

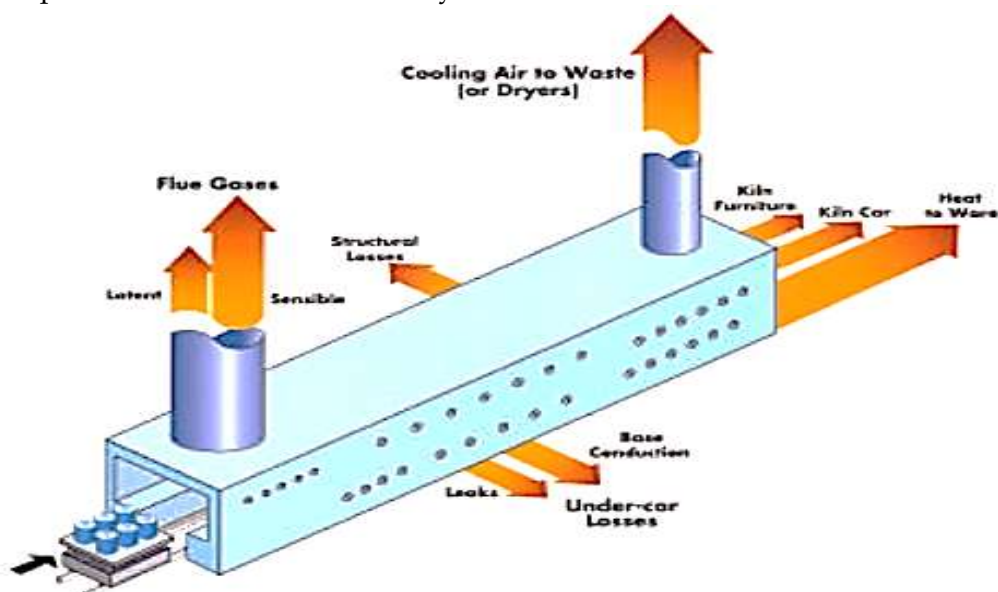

It may be observed that about 50% of the energy is lost through the kiln combustion flue gas and cooling gas stacks. In the present scenario the residual heat of the gases from the cooling stack is mainly reused. Since these gases consist of air without pollutants result from the direct contact of the air used to reduce the tile temperature in the cooling zone. Other losses like radiation, losses due to composition of fuel accounts for about (10 to 30%). The heat losses clearly indicate significant potential to reduce the consumption of energy resources as well as scope to improve the competitiveness of the ceramic sector.

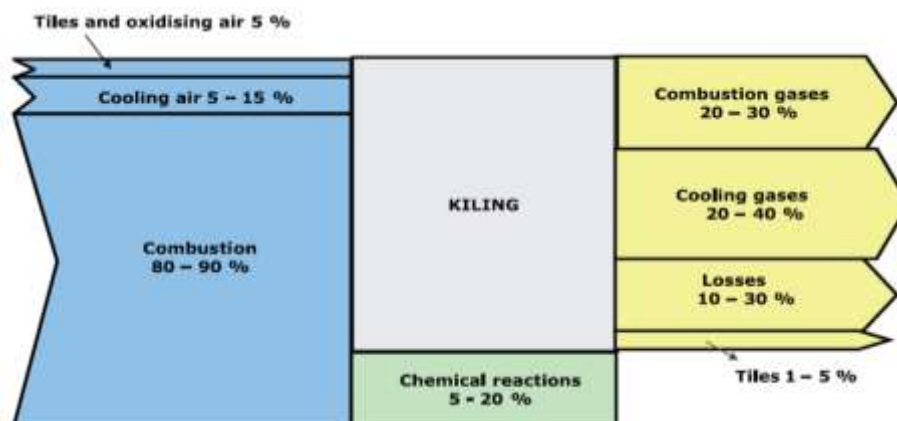

### 5.1.3 Energy conservation and technology options

This section provides detailed assessment of appropriate energy efficient (EE) technologies that would lead to improvement in the performance of kiln and its associated equipment. In the ceramic manufacturing process, kiln account for about 60-70% of the total primary energy consumption in the form of thermal energy. Hence it is one of the focus areas for application of new and efficient technologies. The efficiency of the kiln depends not only on its design parameters but also on operation and requirements for uniform heating.



#### Characteristic diagram of energy optimization, maintenance practices and control system in kiln

The basic concepts of energy conservation in kiln include optimization of combustion, rationalization of heating and cooling, minimization of structural heat losses and recovery of waste heat in flue gases.



The following section provides an overview of technologies that can play a vital role to optimize energy consumption, temperature profile and other operational aspects to improve the quality of the end product.

#### 4.1.4 Energy conservation of thermal energy

Considering the fuel reserves and increasing competition, it is essential to adopt energy conservation measures to improve overall efficiency, reduce operating cost/production cost and minimise the load on energy resources. The efficiency of a kiln will depend on how efficient the combustion system is and secondly how best the generated heat is utilized. Use of standard and good quality fuel improves overall performance of the firing system. Around 5 - 15% energy saving is possible from kilns used in ceramic industries. Some of the potential energy conservation measures (ECMs) for thermal system are listed below.

- Optimum kiln design to ensure capacity utilization to the tune of 98%
- Use of optimum product thickness to reduce heat load for sintering
- Complete combustion with minimum excess air.
- Proper heat distribution.
- Operating the kiln at desired temperature.
- Reducing heat losses from the openings.
- Minimizing wall losses by improving kiln insulation.
- Waste heat recovery from fuel gasses and utilization for drying green products
- Control of Chimney draught and kiln pressure
- Use pre-heating of spray dryer input slurry either solar or electrical heat pump
- Biomass / briquette firing in hot air generation
- Fuel switch over with better option in spray dryer
- Switching to continuous type kilns from intermittent type
- Adopting best operating practices including optimizing of excess air levels
- Use of hot air from cooling zone to preheat input material
- Energy efficient burner that can handle pre-heated combustion air at higher temperature
- Arresting air infiltration in kilns and spray drier system
- Use of lubricants and proper maintenance

Application of ECMs and absolute energy saving would largely depend on the base case scenario and relevant parameters likes operating efficiency of equipment, operating hour, operating load, landing fuel price etc. Some of the applications of ECMs are described below.

#### Air to fuel ratio control in combustion system

Kilns are important segment in ceramic industries and accounting for about 50-65% of energy consumption. Various operating parameters such as temperatures, draft, retention time and material arrangement, etc. may vary with the type of kilns used. Best operating practices are employed to reduce SEC level of a kiln. The operating parameters of kiln along with associated auxiliaries must be maintained appropriately close to design/standard

values. BOPs have significant influence on energy use and changes in operating practices within the limitations of kiln design and associated equipment may help in reducing specific energy consumption.

Monitoring of operating parameters and periodic maintenance are essential elements for achieving optimum performance and energy use. It is significant to monitor the performance of kiln parameters in order to identify the need for careful attention for maintenance which can help to sustain efficient use of energy. In addition to regular maintenance and fine-tuning/ calibration of associated control system, it is also recommended to undertake rigorous monitoring of kiln on a regular basis. The plant may prepare schedule for examining the set points and calibration of the kiln control system as well as the auxiliaries. The recommended period for the calibration is generally 6-12 months depending on the sensitivity of the system/sensors used and the level of the periodic maintenance schedule adopted. Such type of practices would help operator/supervisor to analyze the specific energy use and also indicate the deteriorations or improvements in performance. This section provides the O&M practices essential to be followed and BOPs that are applicable for different types of kiln.

More the air is used to burn the fuel, more is the heat wasted in heating air. Air, slightly in excess of ideal stoichiometric (or theoretical) fuel to air ratio is required for complete combustion and to reduce NO<sub>x</sub> emissions; it is dependent on the type of fuel. However, excess air beyond the optimum range (an efficient natural gas burner however requires 2% to 3% excess oxygen, or 10% to 15% excess air in the flue gas, to burn fuel without forming carbon monoxide)

may substantially decrease combustion efficiency as it leads to generation of excessive waste gases. The effect of excess air level and flue gas temperature on dry flue gas losses is shown in graph

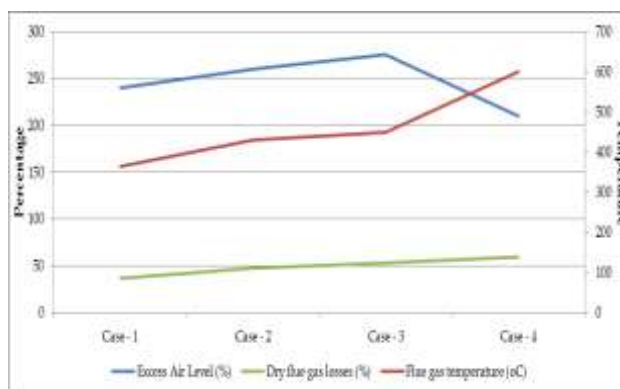

Excess air vs dry flue gas loss

The relationship between the air-to-fuel ratio and wasted heat energy provides a basis for control system design. In most of the cases, real combustion processes have inadequate mixing of air with fuel. Also, the gases tend to flow so quickly that the air and fuel mix have limited contact time in the combustion zone. As such, if air is fed in exact theoretical or stoichiometric proportion to the fuel, it will still lead to incomplete combustion. Automatic burner assembly generally performs in a manner similar to the graph. The cost associated with operating at increased air-to-fuel ratio is the energy wasted in heating additional air volume. Yet, if the air-to-fuel ratio is decreased, losses due to incomplete combustion and emission will increase rapidly.

Too Little Air Increases Pollution and Wastes Fuel	Too Much Air Wastes Fuel
<p>↳ If the air-to-fuel ratio is too small, there will not be enough oxygen available to completely convert the hydrocarbon fuel to carbon dioxide and water. Too small air-to-fuel ratio leads to incomplete combustion of fuel. As the availability of oxygen decreases, noxious exhaust gases including carbon monoxide will be formed first. As the air-to-fuel ratio decreases further, partially burned and unburned fuel may appear in the exhaust stack, often revealing itself as smoke and soot.</p>	<p>↳ The issue that makes operation of a combustion process so interesting is that if feed air to the combustion zone is high (if the air-to-fuel ratio is too high), waste of fuel, though in a wholly different manner. Once enough oxygen available in the burn zone to complete combustion of fuel, it would have addressed the pollution portion of combustion chemistry equation. However, any air fed to the process above and beyond that amount becomes an additional process load to be heated.</p>
<p>↳ Incomplete combustion also means wasting expensive fuel. Fuel that does not burn to provide useful heat energy, including carbon monoxide that could yield energy as it converts to carbon dioxide, literally flows up to exhaust stack as lost profit.</p>	<p>↳ As the air-to-fuel ratio increases above that needed for complete combustion, the extra nitrogen and unneeded oxygen absorb heat energy, decreasing the temperature of flame and gases in combustion zone. As the operating temperature drops, less extraction of useful heat energy for intended applications.</p>

Kiln thermal parameters controller comprises kiln temperature, pressure and atmosphere controlling. In different stages, the control act differently, in firing process, PLC control inverter adjust the combustion fan to change air flowing in air hose. Electric valve of fire nozzle is set by numerical program to setup kiln atmosphere during heating process.

In the cooling stage, NG is shut down and each fire valves/nozzle is closed automatically. The temperature controller switch to the cooling control

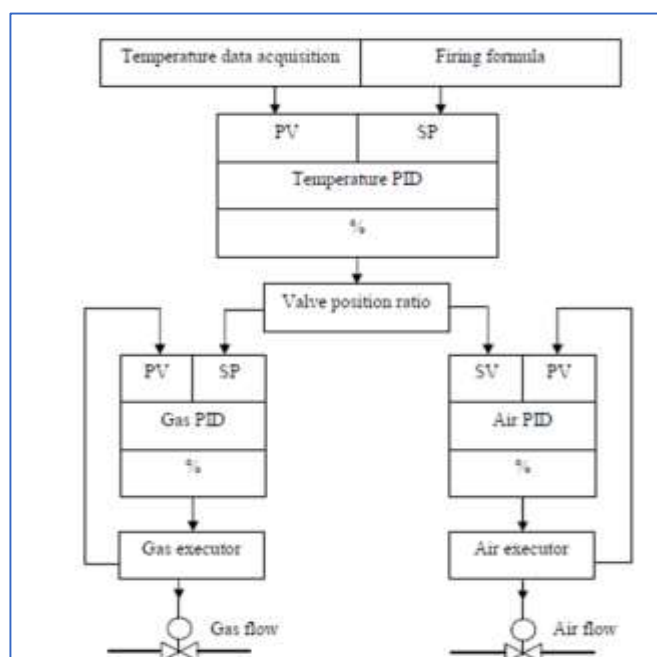

mode and the system enters cooling stage. In this period, air general pipe is controlled by opening degree.

Fire nozzles are divided into two groups. In order to reduce cost, temperature valve position automatic control is used as shown in Figure. Each gas general hose has gas solenoid valve

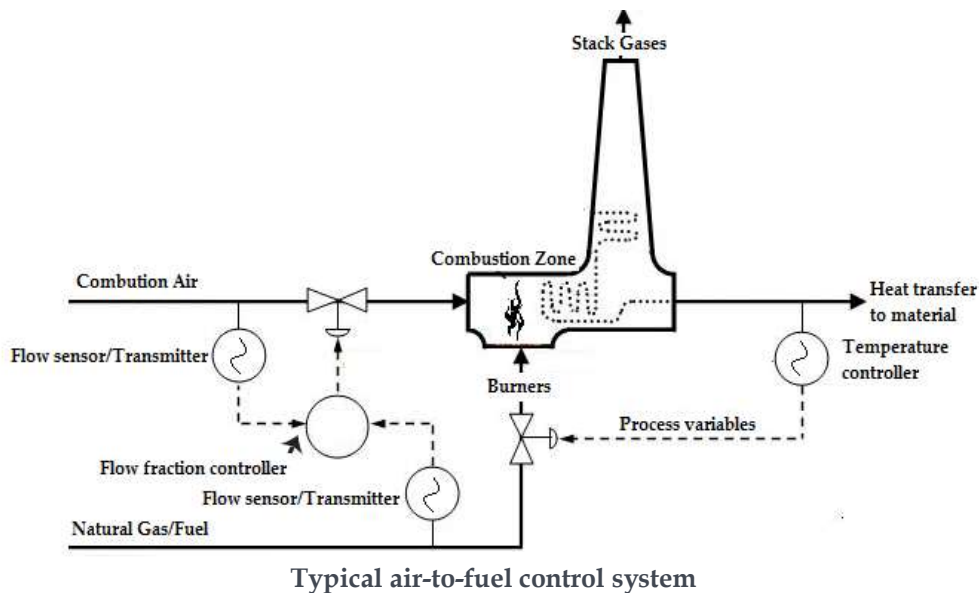

and each group of gas general hose and combustion general hose is installed with electric executor. This compares the air-fuel ratio practical value (PV measured by thermocouples) with set value (SV) and controls gas executor and combustion executor by PID regulator. Temperature PID controller controls firing by controlling air flow and gas flow which are accomplished by the opening degree of combustion air valves and gas valves.

### Benefits of combustion control

- Reduce excess fuel consumption.
- Reduce blower power consumption
- Increases exhaust temperature
- Give higher benefits in preheated combustion air as well as in dryer applications

Reduction of the excess air flow rate leads to a reduction in kiln energy consumption, though this operation must be performed with care, because other kiln operating parameters could be affected. It has been experimentally verified that 2% reduction in the oxidising air flow rate entails a decrease of the order of 5% in the natural gas flow rate.

### Use of low thermal mass material

Heavy refractory cars and saggars are generally used for carrying ceramic products inside the kiln. The dead weight of the refractories is quite high (around 24%). These refractories which

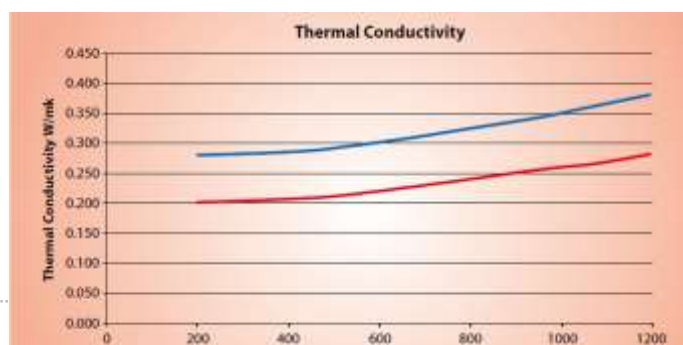

do not take part in reactions in formation of ceramic products, are subjected to alternate heating and cooling cycles, thereby losing substantial portion of heat input. These heavier refractory cars and saggars can be replaced effectively with low thermal mass cars and decker plates (23 – 24 % weight reduction is possible), which would help in reducing heat losses substantially. The estimated energy saving with use of low thermal mass cars is about 5-10%.

- Use of low thermal mass for kiln cart to **reduces the thermal weight** of the kiln considerably
- Weight reduction in kiln car saves significant amount of energy and also **improve material to car weight ratio**
- Reduces excess the **thermal energy storage** in the kiln furniture (**Roller**)
- Ultralite insulating material with supporting block gives proper support and increase the strength of the kiln base
- Replacing refractory bricks with hollow ceramic coated pipes at the supporting pillars for holding racks
- Dead weight can be cut down to 15 to 25% of the existing weight

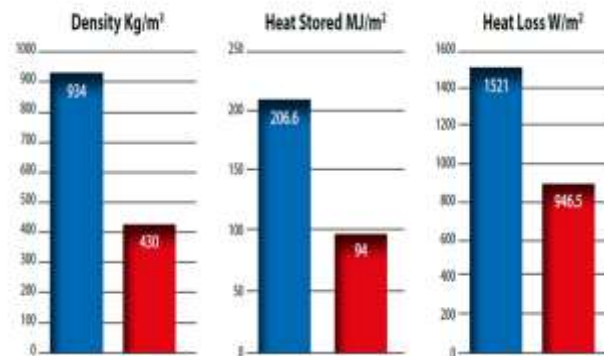

#### Advantages of ultralite insulating material

- High open porosity
- Low thermal mass
- Low permeability
- Low thermal conductivity
- Low bulk density
- Lightweight

#### Improved insulation and refractories of kiln

The efficiency of a kiln is directly dependent of the method of combustion and heat stored within the structure. Apart from the dry flue gas losses, a substantial amount (8-13%) of heat is also lost from walls and material charging and discharging ends. The heat loss from structure can be divided into (i) radiation loss through openings and surface of the body, (ii) loss through roller/car, (iii) heat accumulation loss to internal insulation and supports composing the body. The heat accumulation loss can be ignored for a continuous operation kiln having minimal change in the operating temperature.

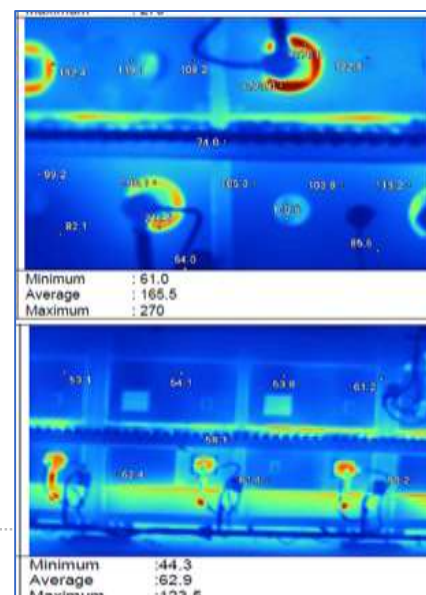

Improvement in the radiation heat loss from surfaces can be achieved by reinforcing its insulation. This includes (i) covering of internal wall surface with ceramic fibre insulation, and (ii) covering external wall surface with ceramic fiber or rock wool insulation.

The temperature gradient i.e. difference between the hot face temperature (hot face temperature is the temperature of the refractory surface in contact with the flue gas or heated combustion air) and surface temperature will be a critical factor for reduction in heat loss by reinforcement of insulation. The hot face temperature is used to determine refractory or insulation thickness and heat transmitted. The design temperature is used to specify the service temperature limit of refractory materials.

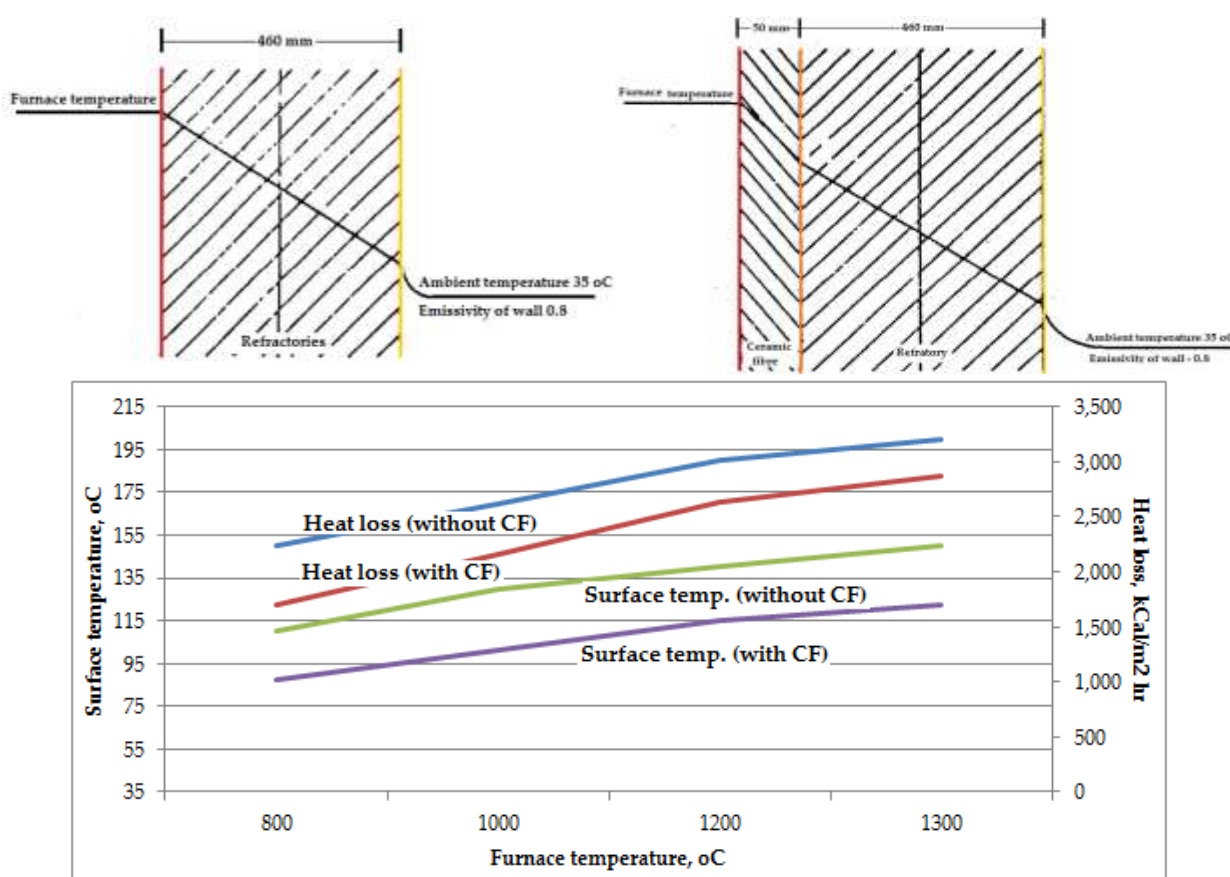

Effect of insulation in a kiln: Heat loss vs surface temperature

Use of better insulation material would further help in improving the thermal efficiency of kilns. The overall energy saving potential of kilns is about 2-3%.

### Waste heat recovery in kiln

In the existing practices, the quantity of heat taken away from a kiln by high temperature flue gases is quite large. This can be reduced by adopting two methods, one is to reduce the volume of exhaust gas, and the other is to reduce the temperature of exhaust gas. The former is optimization of air-fuel ratio. The second method is through recovering waste heat

available in outgoing flue gas. One of the conventional, economical and convenient methods is use of centralized recuperator system for preheating of combustion air.

Recuperator is a mechanical device in which heat exchange takes place between the flue gases and the combustion air through metallic or ceramic walls. Ducts or tubes carry the air for combustion for preheating whereas the other side contains the waste heat (flue gas) stream. There are many types of the waste heat recovery recuperator depending on the application. The most common types of recuperator include metallic radiation recuperator, convection recuperator, hybrid recuperator and ceramic recuperator.

The most commonly recuperator used is convection type. Convection recuperator (also referred to as “flue” or “canal” recuperator) is tubular heat exchangers that utilize convection heat transfer to preheat combustion air for the purpose of saving fuel. By recovering heat from the hot waste gas exiting the kiln and transferring it to combustion air feeding the burners, fuel usage can be reduced up to 5-15%.

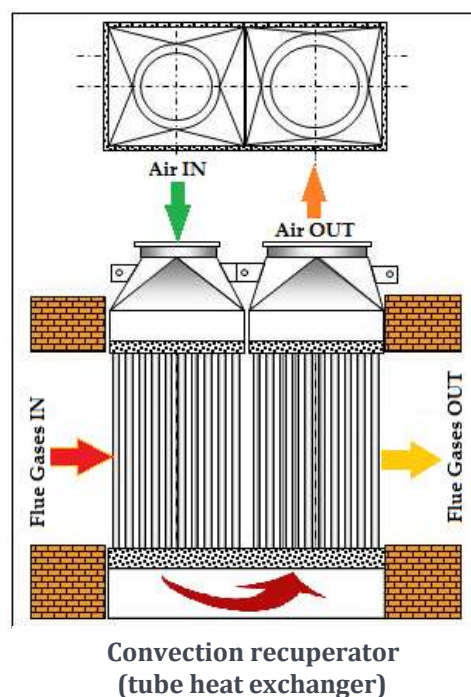

#### Use of energy efficient & high preheated air temperature burners

Use of high velocity energy efficient burner's and high preheated air temperature burners further improves kiln efficiency. Observed maximum preheated air temperature in the kiln in Morbi cluster is 250 0C, whereas current burner technology accepts air preheat temperature upto 600 0C. This offers good opportunity for high temperature waste heat recovery. Higher the combustion air temperature, lower will be the fuel consumption in the kiln.

(Source: Manual on Energy Conservation Measures in Ceramic Industry, BEE SME Programme)

#### 4.1.5 Other key recommendations/tools

##### Optimum capacity utilization

The capacity utilization (commonly known as “loading”) of a kiln is one of the key factors affecting the efficiency. The loading of a kiln includes preparation of material to feed, amount of material placed, arrangement inside the kiln and the residence time inside the kiln.

##### Optimum arrangement of load

The feedstock on the hearth should be arranged in such a manner that:

- ✓ It receives maximum amount of radiation from the hot surfaces of the heating chambers and flames
- ✓ Hot gases are efficiently circulated around the heat receiving surfaces of the materials

Stock should not be placed in the following positions:

- ☒ In the direct path of the burners or where impingement flame is likely to occur
- ☒ In an area that is likely to cause a blockage or restriction of the flue system of the kiln
- ☒ Close to any door openings where cold spots are likely to develop

### **Raw Material Processing**

- ✓ Purchase the right materials, it will save the energy and costs that would otherwise have to be incurred to treat them in the unit
- ✓ Raw material is transported to the processing areas by conveyers: do not let the conveyor ON when there is no material to be transported.
- ✓ Fit timer switches on all the grinding machines so that they automatically switch off after processing of the raw material



## 5.0 Module 4 – Best operating practices and O&M in ceramic industries

### 5.1 Best operating practices (BoPs)

The “best operating practices” (BOPs) is framed with an objective to support in optimizing operating parameters and specific energy consumption close to the design level. Critical and energy consuming equipment/ system/ process are considered under this section. It provides a summary of applicable BOPs which can be followed by ceramic industries.

The purpose of this guide is also to provide the Operations and Maintenance (O&M)/ plant maintenance team and energy practitioner, with useful information about O&M management, technologies, energy efficiency and cost-reduction approaches.



The guiding principle of “Preventive” and “Predictive” maintenance is the regular and systematic application of engineering knowledge and maintenance attention to equipment and facilities to ensure proper functionality, optimize the performance and reduce the rate of deterioration. It encompasses regular examination, inspection, lubrication, testing and adjustments of equipment without prior knowledge of equipment failure. These maintenance practices also provide framework for all planned maintenance activity, including the generation of planned work orders to correct potential problems identified during the inspections. Adoption of these practices in a ceramic industry would lead to a proactive environment, optimizing equipment performance and life.

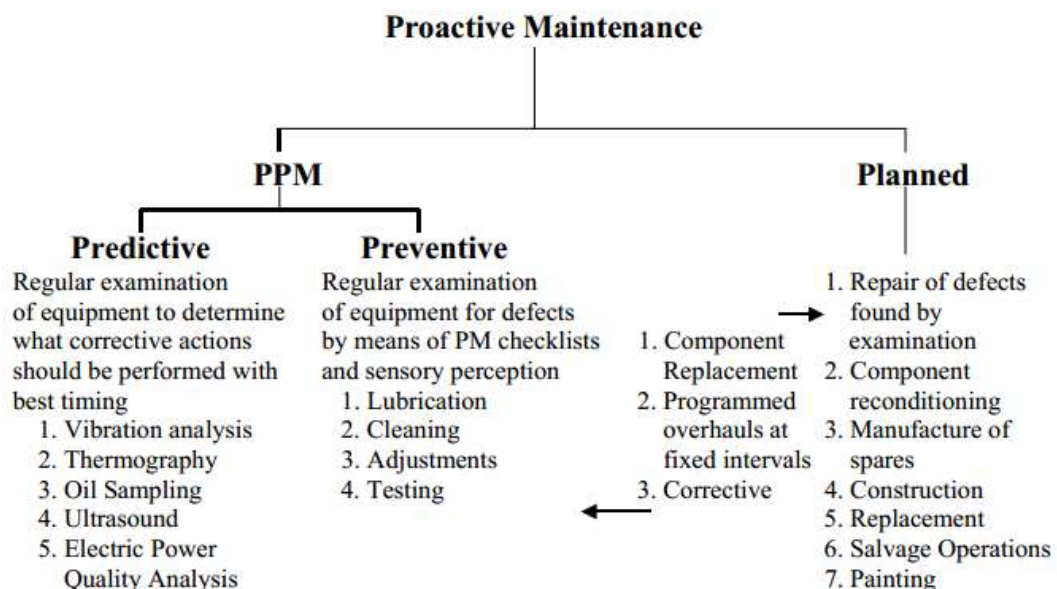

(Source: TERI 2017)

A total proactive maintenance program is essential for efficient, reliable and safe production process. Benefits are direct and substantial, includes the high product quality, long machine life, avoidance of work stoppage and high safety. The essential requirements for proactive maintenance practices are:

- Commitment and leadership
- Compliance and discipline
- Process level intervention to perform regular maintenance checks
- Best operational practices must be instituted to enable the facility to achieve an efficient production system to deliver quality and on time product.

### 5.1.1 Kiln

Kilns are important segment in ceramic industries and accounting for about 50-65% of energy consumption. Various operating parameters such as temperatures, draft, retention time and material arrangement, etc. may vary with the type of kilns used. Best operating practices are employed to reduce SEC level of a kiln. The operating parameters of kiln along with associated auxiliaries must be maintained appropriately close to design/standard values. BOPs have significant influence on energy use and changes in operating practices within the limitations of kiln design and associated equipment may help in reducing specific energy consumption.

Monitoring of operating parameters and periodic maintenance are essential elements for achieving optimum performance and energy use. It is significant to monitor the performance of kiln parameters in order to identify the need for careful attention for maintenance which can help to sustain efficient use of energy. In addition to regular maintenance and fine-tuning/ calibration of associated control system, it is also recommended to undertake rigorous monitoring of kiln on a regular basis. The plant may prepare schedule for examining the set points and calibration of the kiln control system as well as the auxiliaries. The recommended period for the calibration is generally 6-12 months depending on the sensitivity of the system/sensors used and the level of the periodic maintenance schedule adopted. Such type of practices would help operator/supervisor to analyze the specific energy use and also indicate the deteriorations or improvements in performance. This section provides the O&M practices essential to be followed and BOPs that are applicable for different types of kiln.

#### Air-to-fuel ratio

A ratio control technique/practice can play an important role in optimum and profitable operation of kiln and similar processes. The air-to-fuel ratio in the combustion zone directly impacts fuel combustion efficiency and emissions. A requirement for ratio control technique implementation is that both the fuel supply rate and combustion air flow rate are measured and available as process variable indicators. A typical air to fuel ratio control system is shown below.

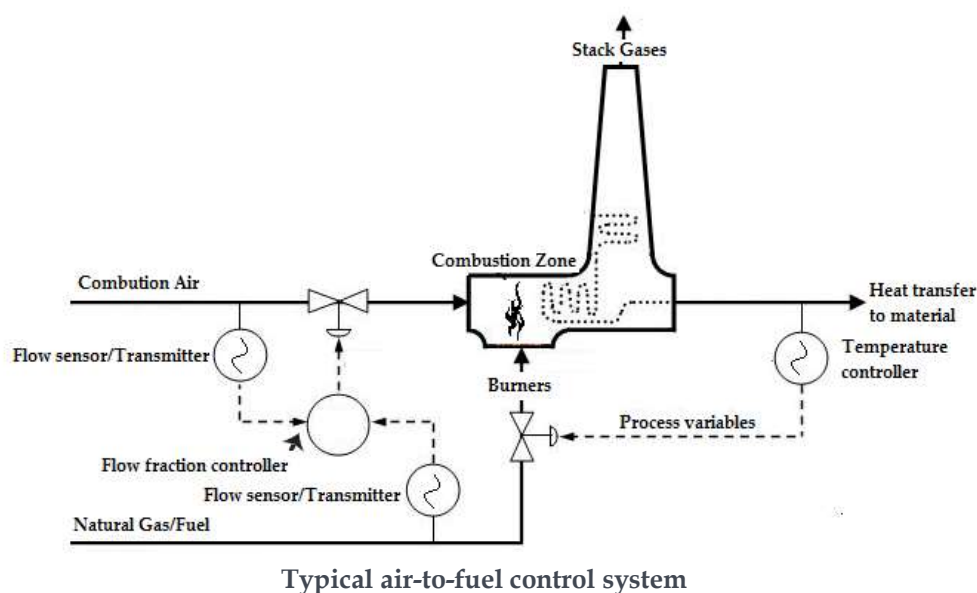

(Source: TERI 2017)

In the combustion process, air-to-fuel ratio is generally expressed on a mass basis. The maximum useful heat energy is derived by supplying combustion air (stoichiometric or theoretical) that properly matches with the flow rate of fuel to the burner. The fuel flow rate is adjusted to maintain temperatures in different furnace zones. The combustion air flow rate is simultaneously adjusted by a flow fraction controller to maintain the optimum air-to-fuel ratio. The chemical equation for the combustion of fuel is shown below:

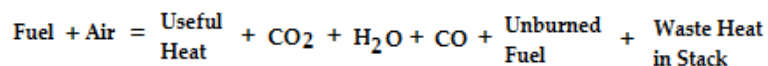

CO<sub>2</sub> - Carbon dioxide  
 CO - Carbon monoxide  
 H<sub>2</sub>O - Water

Air is mainly composed of oxygen (O<sub>2</sub>) and nitrogen. Oxygen combines with carbon in the fuel in a highly energetic reaction called combustion and forms which carbon dioxide (CO<sub>2</sub>), which is the common greenhouse gas (GHG) produced from the complete combustion of hydrocarbon fuel. Water vapour is also a normal product of hydrocarbon combustion.

The relationship between the air-to-fuel ratio and wasted heat energy provides a basis for control system design. In most of the cases, real combustion processes have inadequate mixing of air with fuel. Also, the gases tend to flow so quickly that the air and fuel mix have limited contact time in the combustion zone. As such, if air is fed in exact theoretical or stoichiometric proportion to the fuel, it will still lead to incomplete combustion. Automatic burner assembly generally performs in a manner similar to the graph. The cost associated with operating at increased air-to-fuel ratio is the energy wasted in heating additional air volume. Yet, if the air-to-fuel ratio is decreased, losses due to incomplete combustion and emission will increase rapidly.

Too Little Air Increases Pollution and Wastes Fuel	Too Much Air Wastes Fuel
<p>↳ If the air-to-fuel ratio is too small, there will not be enough oxygen available to completely convert the hydrocarbon fuel to carbon dioxide and water. Too small air-to-fuel ratio leads to incomplete combustion of fuel. As the availability of oxygen decreases, noxious exhaust gases including carbon monoxide will be formed first. As the air-to-fuel ratio decreases further, partially burned and unburned fuel may appear in the exhaust stack, often revealing itself as smoke and soot.</p>	<p>↳ The issue that makes operation of a combustion process so interesting is that if feed air to the combustion zone is high (if the air-to-fuel ratio is too high), waste of fuel, though in a wholly different manner. Once enough oxygen available in the burn zone to complete combustion of fuel, it would have addressed the pollution portion of combustion chemistry equation. However, any air fed to the process above and beyond that amount becomes an additional process load to be heated.</p>
<p>↳ Incomplete combustion also means wasting expensive fuel. Fuel that does not burn to provide useful heat energy, including carbon monoxide that could yield energy as it converts to carbon dioxide, literally flows up to exhaust stack as lost profit.</p>	<p>↳ As the air-to-fuel ratio increases above that needed for complete combustion, the extra nitrogen and unneeded oxygen absorb heat energy, decreasing the temperature of flame and gases in combustion zone. As the operating temperature drops, less extraction of useful heat energy for intended applications.</p>

### Optimum capacity utilization

The capacity utilization (commonly known as “loading”) of a kiln is one of the key factors affecting the efficiency. The loading of a kiln includes preparation of material to feed, amount of material placed, arrangement inside the kiln and the residence time inside the kiln.

### Optimum arrangement of load

The feedstock on the hearth should be arranged in such a manner that:

- ✓ It receives maximum amount of radiation from the hot surfaces of the heating chambers and flames
- ✓ Hot gases are efficiently circulated around the heat receiving surfaces of the materials

Stock should not be placed in the following positions:

- ☒ In the direct path of the burners or where impingement flame is likely to occur
- ☒ In an area that is likely to cause a blockage or restriction of the flue system of the kiln
- ☒ Close to any door openings where cold spots are likely to develop

### Check list

- ↪ Check the concentration of oxygen in flue gases, which is an indication for excess air level for combustion of fuels. If the level is high, check for air infiltration
- ↪ Check the level carbon monoxide in flue gases which indicates combustion efficiency or the un-burnt that affect thermal efficiency of furnace
- ↪ The air to fuel ratios at high and low firing conditions
- ↪ The burners are not over-rated and should be able to operate at low fire condition throughout the production campaign
- ↪ There is adequate mixing of air and fuel at the burner
- ↪ Check pre-heated air temperature which indicates the condition of recuperator and cleaning requirements.

### Raw Material Processing

- ✓ Purchase the right materials, it will save the energy and costs that would otherwise have to be incurred to treat them in the unit
- ✓ Raw material is transported to the processing areas by conveyers: do not let the conveyor ON when there is no material to be transported.
- ✓ Fit timer switches on all the grinding machines so that they automatically switch off after processing of the raw material

### Ball mill

- ✓ Always operate the ball mill at its critical loading point. The material loading of the ball mill is a critical parameter in determining the energy consumption. Specific Energy Consumption will increase if the ball mill is loaded below/above the critical loading point.
- ✓ Irrespective to the size of ball mill, ceramic lined mill, pebble mill, jar mill or laboratory jar rolling mill, its rotational speed is important to proper and efficient mill operation.
  - Too low a speed and little energy is imparted on the product. Too fast and inefficient media movement will generate high impact but also greatly increase mill wear.
  - Even faster speed will result in the media centrifuging inside the mill and virtually no milling or movement of media or product will occur. In most cases, the ideal mill speed will have the media tumbling from the top of the pile (the shoulder) to the bottom (the toe) with many impacts along the way.
  - The ideal mill speed is usually somewhere between 55% to 75% of critical speed.

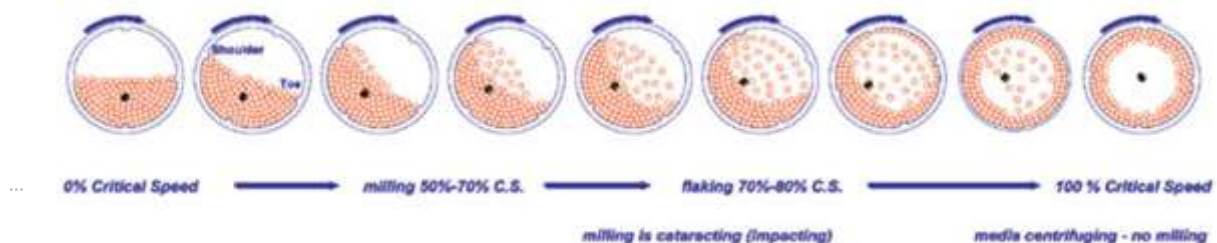

- ✓ Use grinding media (pebbles) in three different sizes for better and efficient grinding of raw material.
- ✓ Check the mesh size of the slurry - when it reaches the required value, switch off ball mill/blunger.
- ✓ Regularly monitor batch time.
- ☒ Don't blend the clay two or three days in advance.

### Spray dryers

- ✓ The particle size of the pulverized coal should be optimized and should be checked regularly.
- ✓ Check and clean the nozzles regularly.
- ✓ VFD should be installed on the ID fan and provide the sensor with respect to the temperature of flue gas and the pressure in the spray dryer.
- ✓ Particle size of coal should be kept similar & should be checked periodically
- ✓ To maximize the raw material slurry conversion into powder form, following are the necessary parameters
  - Air circulation should maintain ratio and synchronize with feed pump
  - Flow of slurry and temperature of air should be optimized
- ✓ Avoid air ingress in hot air generator system

### Press

- ✓ Maintain suitable pressure settings in the press machine. The amount of pressure to be applied depends upon the type of product being manufactured.
- ✓ Installation of VFD on press hydraulic motor can save electricity consumption in the press.
- ✓ Installation of vacuum dust collector avoids the wastage of the raw material and also the energy required for reprocessing it.
- ✓ If possible, operate press machine in off peak hours to benefit from time of use tariff.
- ✓ Maintain the moisture content at the required level in the powdered raw material for proper processing from the press.
- ✓ Inspect the output from the press. This will ensure that defective material is not dried or fired in the kiln.

## 5.1.2 Utilities

### Compressed air system and distribution network

The delivery pressure of compressors is generally 1.1 kg/cm<sup>2</sup> (100 kPa) or higher. Compressed air systems are usually designed to operate within a fixed pressure range and to deliver a volume of air that varies with system demand. Compressed air needs are defined by air quality, quantity and pressure level

Quality	Applications
Plant Air	Air tools, general plant air
Instrument Air	Laboratories, paint spraying, powder coating, climate control
Process Air	Food, pharmaceutical, electronics etc.

required by the end use points. Analysing needs carefully will ensure that a compressed air system is configured properly.

**Air quality:** The quality of compressed air is determined by dryness and contaminant level permissible at end use and need is to be accomplished using drying and filtering equipment. Higher the quality more cost to produce air. Typical air quality for various industrial

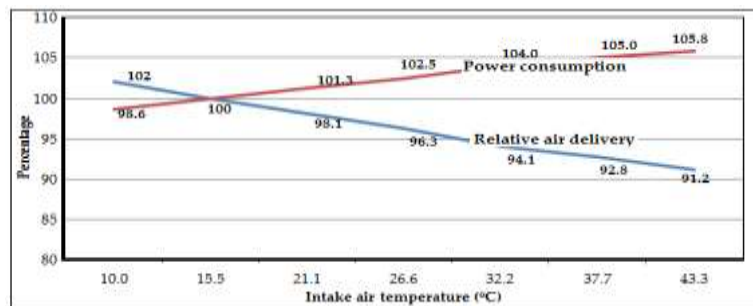

Effect of intake air temperature on performance

applications is shown in table. High quality air usually requires additional equipment, which not only increases initial capital investment, but also makes the overall system more expensive to operate in terms of energy consumption and maintenance costs.

**Intake air:** The air entering compressor should be as cool as possible to maintain the specific power consumption at design because cold air is denser than warm air. The colder the incoming air, the more the air molecules there are, so that more air is compressed for each revolution of the air compressor. Also the cooler the incoming air, the lesser the requirements for intercooling and after cooling. The compressor room should also be cleaner and cooler for optimum compressor operation.

*For about 4 °C rise in intake air temperature, the power consumption increases by about 1% for the same air delivery.*

**Generation pressure:** System pressure is monitored and control system decreases the compressor output when the pressure reaches a pre-set level. Compressor output is increased again when the pressure drops to a lower value than the pre-set. The difference between these two pressure levels is called the control range. Depending on pressure requirement at utilization end, the control range can be anywhere from 0.15-1.5 kg/cm<sup>2</sup>. To optimize the generation cost of the compressed air selection of appropriate capacity and reduction in delivery pressure are two critical parameters. (Source: TERI 2017)

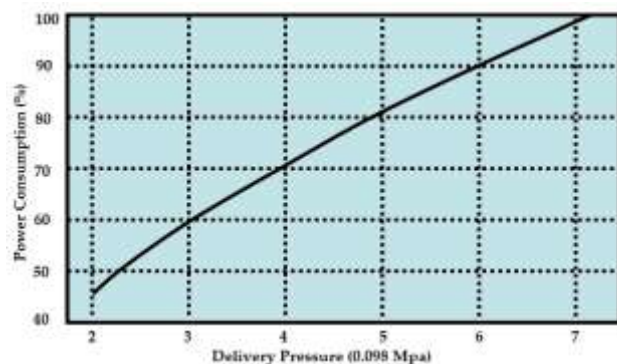

Power consumption vs delivery pressure

*A rule of thumb for systems in the 7.0 kg/cm<sup>2</sup> range is for every 0.15 kg/cm<sup>2</sup> increase in discharge pressure, energy consumption will increase by approximately 1 per cent at full output flow.*

Raising the compressor discharge pressure increases the demand of every unregulated usage, including leaks, open blowing, etc. Although it varies from plant to plant, unregulated usage is commonly as high as 30-50% of air demand.

**Prevention of leakages:** Compressed air system leak repair program is very important to maintaining the efficiency, reliability, stability and cost effectiveness of compressed air system. One of the best practices to avoid the losses due to leakages in compressed air distribution network is leak prevention activities. There are two basic types of leak repair activities, the “leak tag” and “seek and repair”. The “seek and repair” is the simplest method which allows the team to find the leaks and repair them immediately. The “leak tag” involves the tagging the identified and logging for repair at a later time. Both the activities may be undertaken during the preventive maintenance practices and/or the plant may regularly conduct the leakage test to identify the activities to be performed to repair the leak.

**O&M Practices and schedule:** Most of the ceramic industries in the country use lubricant-injected rotary compressor. The general O&M practices and the schedule to perform the practices in lubricant-injected rotary compressor are given in table.

Period	Activities
Periodically/Daily (8 Hours Maximum)	<ul style="list-style-type: none"> <li>▪ Monitor all gauges and indicators for normal operation</li> <li>▪ Check lubricant level and top off as necessary</li> <li>▪ Check for lubricant leaks</li> <li>▪ Check for unusual noise or vibration</li> <li>▪ Drain water from air/ lubricant reservoir</li> <li>▪ Drain control line filter.</li> </ul>
Weekly	<ul style="list-style-type: none"> <li>▪ Check safety valve operation</li> </ul>
Monthly	<ul style="list-style-type: none"> <li>▪ Service air filter as needed</li> <li>▪ Wipe down entire unit to maintain appearance</li> <li>▪ Check drive motor current at full capacity and design pressure</li> <li>▪ Check operation of all controls</li> <li>▪ Check operation of lubricant scavenger/return system and clean as necessary.</li> </ul>
Half-yearly or every 1,000 Hours	<ul style="list-style-type: none"> <li>▪ Take lubricant sample</li> <li>▪ Change lubricant filter. Manufacturers may recommend changing the lubricant filter within the first week of operation to rid the system of foreign particles which may have been collected during initial assembly and start-up.</li> </ul>
Annually/ Periodically	<ul style="list-style-type: none"> <li>▪ Go over unit and check all bolts for tightness</li> <li>▪ Change air/lubricant separator</li> <li>▪ Change air filter</li> <li>▪ Lubricate motors per manufacturer’s instructions</li> <li>▪ Check safety shutdown system. Contact authorized serviceperson.</li> </ul>



### 5.1.3 Motor maintenance

Electric motors fail for a variety of reasons. Certain components of motors degrade with time and operating stress. Electrical insulation weakens over time with exposure to voltage unbalance, over and under-voltage, voltage disturbances, and temperature. Contacts between moving surfaces cause wear. Wear is affected by dirt, moisture, and corrosive fumes and is greatly accelerated when lubricant is misapplied, becomes overheated or contaminated, or is not replaced at regular intervals. When any components are degraded beyond the point of economical repair, the motor's economic life is ended. An electric motor performs efficiently only when it is maintained and used properly. Electric motor efficiencies vary with motor load; the efficiency of constant speed motor decreases as motor load decreases. Below are some general guidelines for efficient operations of electric motors.

**Turn off unneeded motors:** Locate motors that operate needlessly, even for a portion of the time they are on and turn them off. For example, there may be multiple HVAC circulation pumps operating when demand falls, cooling tower fans operating when target temperatures are met, ceiling fans on in unoccupied spaces, exhaust fans operating after ventilation needs are met.

**Sizing motors:** It is necessary to assess the actual loading of existing motors especially when replacing motors. Many motors operate most efficiently in the range of 75-85% of full load rating. Under-sizing or over-sizing will lead to operate at reduced efficiency.

**Replacement of motors versus rewinding:** Instead of rewinding small motors, consider replacement with an energy efficient version. For larger motors, if motor rewinding offers the lowest life-cycle cost, select a rewind facility with high quality standards to ensure that motor efficiency is not adversely affected.

**Preventive and predictive maintenance:** These maintenance procedures involve a sequence of steps to be used to prolong motor life or foresee a motor failure. Predictive maintenance programs for motors observe the temperatures, vibrations and other data to determine a time for overhaul or replacement of the motor. Preventive maintenance takes steps to improve motor performance and to extend its life. Common preventive tasks include routine lubrication, allowing adequate ventilation and ensuring the motor is not undergoing any type of unbalanced voltage situation etc.

Most motor cores are manufactured from silicon steel or de-carbonized cold-rolled steel, the electrical properties of which do not change measurably with age. However, poor maintenance can cause deterioration in motor efficiency over time and lead to unreliable operation. The general O&M practices and the schedule to perform the practices in electric motor is given in table.

Period	Activities
Periodically/Change in duty cycle	<ul style="list-style-type: none"> <li>▪ Turn off/sequence unnecessary motors</li> <li>▪ Complete overall visual inspection to be sure all equipment is operating and safety systems are in place</li> <li>▪ Check load conditions to avoid the over or under loading conditions due to change in duty cycle or associated load profile</li> <li>▪ Check for alignment of the motor and the driven equipment. Improper alignment can cause shafts and bearings to wear quickly, resulting in damage to both the motor and the driven equipment</li> </ul>
Weekly	<ul style="list-style-type: none"> <li>▪ Check condition of motor through temperature or vibration analysis and compare to baseline values</li> </ul>
Monthly	<ul style="list-style-type: none"> <li>▪ Assure that all bearings are lubricated per the manufacture's recommendation</li> <li>▪ Check packing for wear and repack as necessary. Consider replacing packing with mechanical seals.</li> <li>▪ Aligning motor coupling allows for efficient torque transfer to pump</li> <li>▪ Check and secure all motor mountings</li> <li>▪ Tighten connection terminals as necessary</li> <li>▪ Remove dust and dirt from motor to facilitate cooling</li> </ul>
Annually Periodically	<ul style="list-style-type: none"> <li>▪ Ensure that supply wiring and terminal box are properly sized and installed</li> <li>▪ Inspect regularly the connections at the motor and starter to be sure that they are clean and tight</li> <li>▪ The life of the insulation in motor would also be longer; for every 10°C increase in motor operating temperature over the recommended peak, the time before rewinding would be needed is estimated to be halved.</li> <li>▪ Over- or under-voltage situations can shorten the motor life through excessive heat build up</li> </ul>

### 5.1.4 Cooling towers

Cooling tower maintenance must be an ongoing effort which otherwise may result in system degradation, loss of efficiency and potentially serious health issues. The common causes of poor performance of cooling towers include the following:

- **Scale deposits:** Water evaporates from the cooling tower leaves scale deposits on the surface of the fills (heat exchange media). Scale build-up reduces heat transfer area and acts as a barrier to heat transfer from the water to the air.
- **Clogged spray nozzles:** Algae and sediment collected in the water basin as well as excessive solids in process water can clog the spray nozzles. This causes uneven water distribution over the fill, resulting in uneven airflow through the fill and reduced heat transfer surface area.

- **Poor air flow:** Poor airflow through cooling tower reduces heat transfer rate from water to air. It can be caused by debris at the inlets or outlets of the tower or in the fill. Other possible causes of poor airflow includes loose fan and motor mountings, poor motor and fan alignment, poor gear box maintenance, improper fan pitch, damage to fan blades or excessive vibration.
- **Poor pump performance:** Proper water flow is important to achieve optimum heat transfer. Loose connections, failing bearings, cavitation, clogged strainers, excessive vibration and non-design operating conditions result in reduced water flow, reduced efficiency and premature equipment failure.

The following are the key O&M practices to be adopted to achieve the efficient operation of cooling towers.

Period	Activities
Daily	<ul style="list-style-type: none"> <li>▪ Inspect and remove any accumulated debris before starting the cooling tower</li> <li>▪ Before starting the fan motor, check the tightness and alignment of drive belts, tightness of mechanical hold-down bolts, oil level in gear reducer drive systems, and alignment of couplings</li> <li>▪ Blow down water rate from the cooling tower should be adjusted to maintain between two to four concentrations of total dissolved solids (TDS).</li> </ul>
Monthly	<ul style="list-style-type: none"> <li>▪ Check cooling water to avoid formation of algae and increase in TDS level. Use the water treatment chemical addition as recommended by water treatment agency after the testing of the water quality.</li> </ul>
Half yearly	<ul style="list-style-type: none"> <li>▪ Balance water flow as per the guidelines provided by the manufacturer to ensure even distribution of hot water to all areas of the fill material. Poorly distributed water may also lead to air bypass through the fill and loss of performance.</li> </ul>
Annually/ Periodically	<ul style="list-style-type: none"> <li>▪ To avoid the hotspots, infrared thermal imager should be used for accurate, non-contact assessment of temperatures. It should include key parts such as bearing and electrical contact assessments on motor and fan systems as well as belt and other drive systems.</li> </ul>

### 5.1.5 Pumping system

There are a number of operational measures that can be adopted for proper pump operation and control. The most prevalent O&M recommendations having the greatest energy impacts and life of the system includes the following

**Eliminating flow control valve:** In conventional of general practices, control the flow by closing or opening the discharge valve (this is also known as “throttling” the valves). While this method reduces the flow, it does not reduce the power consumption, as the total head (static head) increases. This method increases vibration and corrosion and thereby increases

maintenance costs of pumps and potentially reduces their lifetimes. It is always recommended to use the variable speed tools to control the flow.

**Eliminating by-pass control:** The fluid flow can also be regulated by installing a by-pass control system, in which the discharge of the pump is divided into two flows going into two separate pipelines. In other words, part of the fluid is pumped around for no reason, and thus is energy inefficient. Because of this inefficiency, this option should therefore be avoided.

**Impeller trimming:** Impeller trimming is one of the methods to reduce the flow permanently. Changing the impeller diameter gives a proportional change in the impeller’s peripheral velocity. Changing the impeller diameter is an energy efficient way to control the pump flow rate. However, this method required some of the preliminary consideration includes the following:

- Not suitable for varying flow patterns.
- Impeller should not be trimmed by more than 25% of the original impeller size
- The balance of pump has to been maintained, i.e. the impeller trimming should be the same on all sides.
- Changing the impeller itself is a better option than trimming, which however is expensive and sometimes the next smaller impeller is too small.

The following are the key O&M practices to be adopted to achieve the efficient operation of pumps.

Period	Activities
Daily	<ul style="list-style-type: none"> <li>▪ Turn off/sequence unnecessary pumps</li> <li>▪ Complete visual inspection to ensure that all equipment is operating and safety systems are in place</li> </ul>
Monthly	<ul style="list-style-type: none"> <li>▪ Assure that all bearings are lubricated per the manufacturers’ recommendation</li> <li>▪ Check packing for wear and repack as necessary. Consider replacement packing with mechanical seals.</li> <li>▪ Aligning the pump/motor coupling allows for efficient torque transfer to the pump</li> <li>▪ Check and secure all pump mountings</li> </ul>
Annually/ Periodically	<ul style="list-style-type: none"> <li>▪ Inspect bearings and drive belts for wear. Adjust, repair or replace as necessary</li> <li>▪ Checking the condition of the motor through temperature or vibration analysis assures long life</li> </ul>

### 5.1.6 Illumination system

Illumination system is one of the areas which do not have significant share of energy consumption in ceramic industries. However, adoption of best practices is required to

maintain the better work environment and other safety aspects. Following are the key operation and maintenance practices necessary for efficient and preferred lux level as per task.

- Use of appropriate selection of lamps and luminaire from the time of the designing and commissioning.
- Establish schedules for re-lamping, cleaning, recalibration and revaluation of the lighting system.
- The ballasts and lighting controls must be specified for factory pre-set to the extent possible.
- Some lighting equipment is designed to task specific which may be sensitive to orientation such as spotlight, wall washers and occupancy sensors. A “pre-application diagram” can be specified or requested prior to installation.

Some maintenance items such as swirling lamps or inoperable ballasts obviously require immediate attention and repair. To maintain the desired properties of the illumination system, following are the key O&M practices to be adopted.

Period	Activities
Need based/One-time analysis	<ul style="list-style-type: none"> <li>▪ Identify areas where day lighting controls could be used</li> <li>▪ Identify areas where local automatic controls could be used</li> </ul>
Monthly	<ul style="list-style-type: none"> <li>▪ Inspect fixtures to identify inoperable or faulty lamps or ballasts. Burned out lamps may damage ballasts if not replaced.</li> </ul>
Half yearly	<ul style="list-style-type: none"> <li>▪ Inspect fixtures and controls to identify excessive dirt, degraded lenses, inoperable or ineffective controls</li> <li>▪ Measure light levels compared to tasks needs in typical spaces. Identify areas for reduction or increase in luminance</li> </ul>
Annually/ Periodically	<ul style="list-style-type: none"> <li>▪ Lamps and fixture reflective surfaces should be cleaned periodically for maximum efficient delivery of light to the space</li> <li>▪ Clean surfaces allow maximum distribution of light within the space</li> <li>▪ For larger facilities consider group re-lamping</li> </ul>